

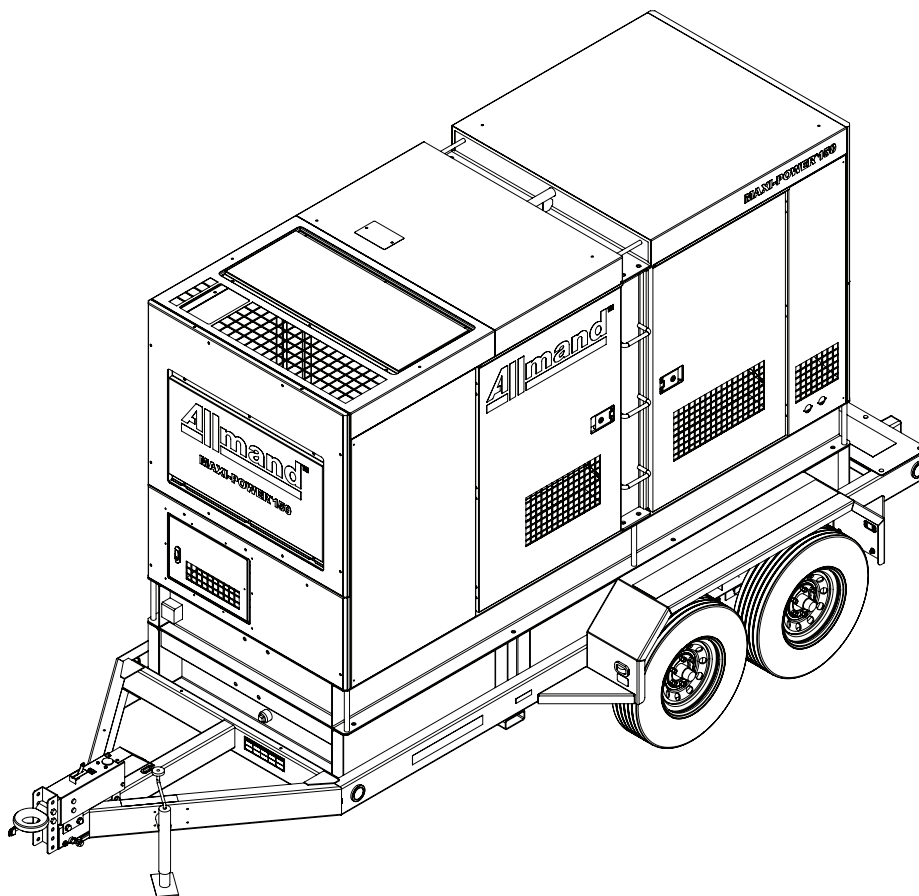

en **Operator's Manual**
Maxi-Power™
Towable Generator
Model MP150 T4F



Thank you for purchasing this quality-built Allmand towable generator. We are pleased that you've placed your confidence in the Allmand brand. When operated and maintained according to the instructions in this manual, your Allmand generator will provide many years of dependable service.

This manual contains safety information to make you aware of the hazards and risks associated with towable generators and how to avoid them. Because Allmand does not necessarily know all the applications this towable generator could be used for, it is important that you read and understand these instructions thoroughly before attempting to start or operate this equipment. **Save these original instructions for future reference.**

Where to Find Us

If you have any questions about the machine, contact your authorized dealer. You can also contact Allmand Customer Service by phone at **(800) 562-1373**, or on the Internet at **allmand.com**.

Knowing the model number of your Allmand Generator will make it easy to order maintenance or repair parts either online or from your local dealer. The model number is generally a number stamped into metal or on a sticker directly on your product.

Towable Generator

Model Number _____

Revision _____

Serial Number _____

Date Purchased _____

Engine

Model Number _____

Type Number _____

Code Number _____

Table of Contents



Safety.....	S-1
Part Names.....	1-1
Installation.....	2-1
Operation.....	3-1
Failure and Troubleshooting.....	4-1
Periodic.....	5-1
Storage and Disposal.....	6-1
Specifications.....	7-1
Operation Log	
Addendum A - Transporting and Setup	AA-1
Addendum B - Cam Locks / Arctic Kit. .	AB-1

Safety

This section explains safety precautions for operation, inspection, maintenance, installation, movement and transportation. Read these safety requirements carefully and fully understand the contents before starting the machine.

For better understanding of the precautions in this manual and on this machine, safety precautions are classified into “DANGER,” “WARNING” and “CAUTION” messages with a warning symbol  marked, according to the degree of hazard.

When one of these messages is found, please take preventive measures for safety and carry out “SAFETY OPERATION AND PROPER MAINTENANCE OF THE MACHINE.”

 DANGER	DANGER indicates an imminently hazardous situation which, if not avoided, will result in death or serious injury.
 WARNING	WARNING indicates a potentially hazardous situation which, if not avoided, could result in death or serious injury.
 CAUTION	CAUTION indicates a potentially hazardous situation which, if not avoided, may result in minor or moderate injury. It may also be used to alert against unsafe practices.
IMPORTANT	IMPORTANT indicates important caution messages for the performance or durability of the machine, which has no concern to injury or accident of or to a human body.

This manual does not describe all safety items. We, therefore, advise you to pay special attention to all items (even though they may not be described in the manual) for your safety.

- ◆ Please tell us the MODEL/SER.No. on the plate of the machine when you make an inquiry.
A plate stamped with the model and serial number is attached to side of the machine.

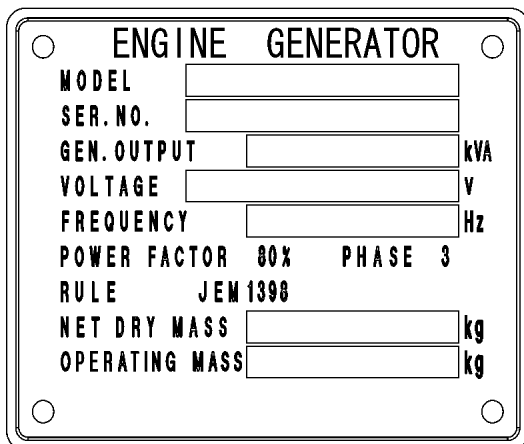

A180077





- ◆ Each illustrated figure (Fig.) has a number (for instance, A180077) at the right bottom. This number is not a part number, but it is used only for our reference number.

Safety



[Safety Warning Labels]

Following labels are attached to the machine.

Keep them clean at all times. If they are damaged or missing, immediately place an order with your nearest dealer for replacement. Part numbers are indicated on the lower right corner of the label. Adhere a new one to the original location.

1	2	3	4	5
				
<p>PREVENT BURNING ACCIDENT When work is required near hot parts, wait for the parts to cool down fully before starting work.</p> <p style="text-align: right;">39176 69500</p>	<p>BEWARE OF ENTANGLEMENT Keep your hands AWAY from moving parts such as V-belts, pulleys etc. Entanglement in them can cause serious injury.</p> <p style="text-align: right;">39176 73800</p>	<p>BEWARE OF ENTANGLEMENT Keep your hands AWAY from fan during operation. Entanglement in the fan can cause serious injury.</p> <p style="text-align: right;">39176 73500</p>	<p>POISON CAUSES SEVERE BURNS Contains sulfuric acid. Avoid contact with skin, eyes or clothing. In event of accident flush with water and call a physician immediately. KEEP OUT OF REACH OF CHILDREN.</p> <p style="text-align: right;">39176 50000</p>	<p>PREVENT BURNING ACCIDENT Do not open radiator cap while it is still hot.</p> <p style="text-align: right;">39176 69600</p>

6	7	8
		
<p>LIFTING BAIL</p> <p style="text-align: right;">39176 69300</p>	<p style="text-align: right;">39176 62000</p>	<p style="text-align: right;">39176 62900</p>

9	10	11
		
<p style="text-align: right;">39178 70940</p>	<p>FLAMMABLES</p> <p style="text-align: right;">39178 22031</p>	<p>BEWARE OF EXHAUST GASES When you operate machine INDOORS or in TUNNEL, provide good ventilation. Poor ventilation can cause fatal accident.</p> <p style="text-align: right;">39176 73300</p>

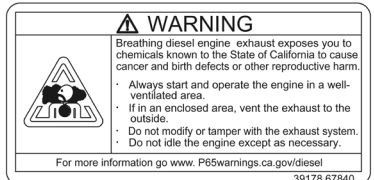
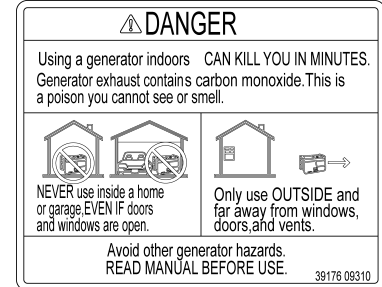
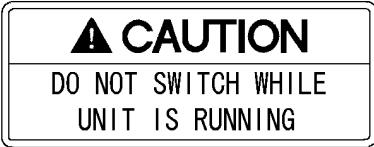
12	13	14
		
<p style="text-align: right;">39178 67840</p>	<p style="text-align: right;">39176 09310</p>	<p style="text-align: right;">39178 50820</p>



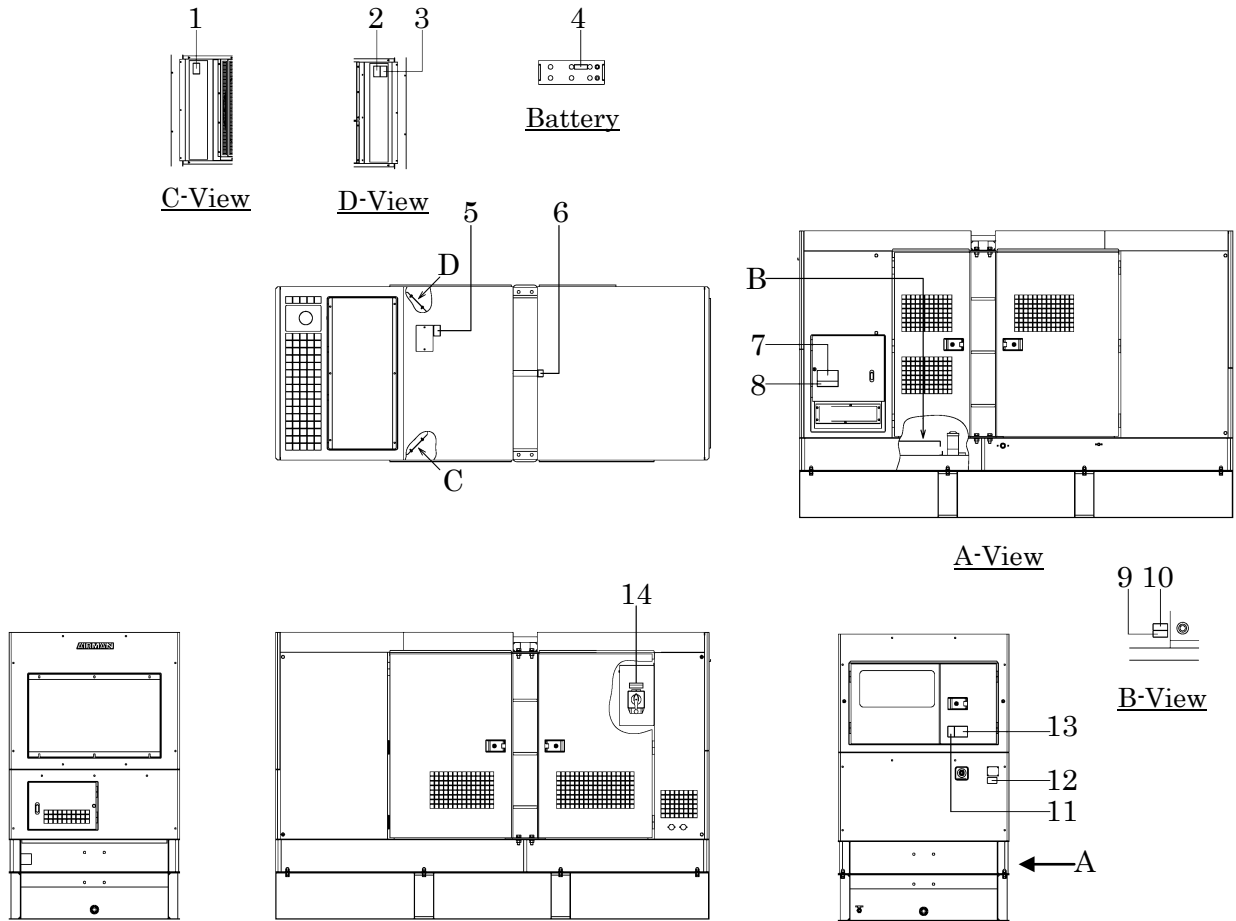

Safety

- The locations of the safety warning labels are as follows.

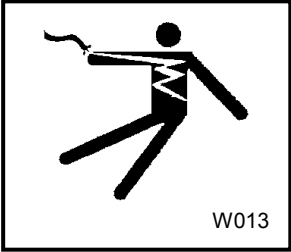

A180076E

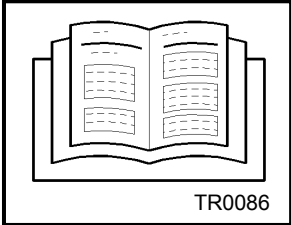
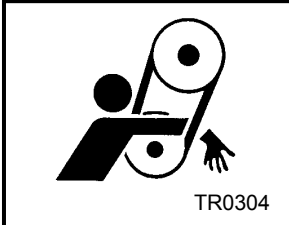
Safety

	 <ul style="list-style-type: none">● Never touch the control panel during operation. Be aware that a voltage of several hundred volts is applied to the control panel.● Be sure to stop the engine and turn control power switch OFF whenever the control panel has to be checked or operated. Disconnect the negative battery terminal during checking and maintenance.
	 <ul style="list-style-type: none">● Read each instruction plate which is displayed in the manual or on the machine carefully, understand its content and follow the indications thereof.● Do not modify the machine without prior approval. The safety may be compromised, functions may be deteriorated, or machine life may be shortened.● Never use the machine for the other purposes than power supply. Otherwise, serious accidents may occur.
	 <ul style="list-style-type: none">● Keep hands off from the rotating machinery or belts while running. It could cause serious injuries to hands.
	 <ul style="list-style-type: none">● When cleaning dust accumulated in devices such as filters, etc., with compressed air, wear safety glasses, etc. to protect your eyes.

Safety

CAUTION

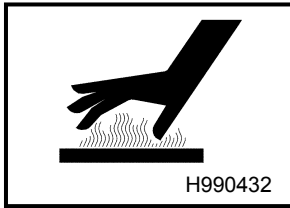

- Be sure to stop the engine, and let the coolant water sufficiently cool down before draining it.
- If the drain valve is opened before the coolant water is cool enough, hot water could jet out, and it could cause scalding.

- When washing the machine, cover the control panel, generator and its electric parts to prevent them from being exposed to splashing water and avoid possible decrease in electrical insulation or other troubles to the machine.
- Dust, sand and dirt accumulated inside control panel could cause malfunction or difficulties with the instruments. Clean them using compressed air.

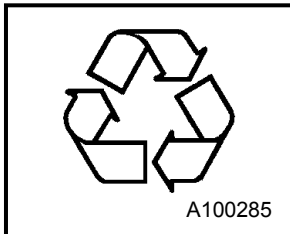

- Waste liquid from the machine contains harmful material. Do not discharge it onto the ground or into the river, lake or sea. Such material will pollute the environment.
- Be sure to use a container to hold waste liquid from the machine.
- Be sure to follow the designated regulations when disposing of oil, fuel, coolant (antifreeze), filter, battery or other harmful materials.

- The engine of this machine contains many electrical and electronic parts. Before welding, be sure to disconnect all electronic control equipment. Failure to do so could result in equipment malfunction due to excessive current.

1. Part Names

1.1 Internal Components and names

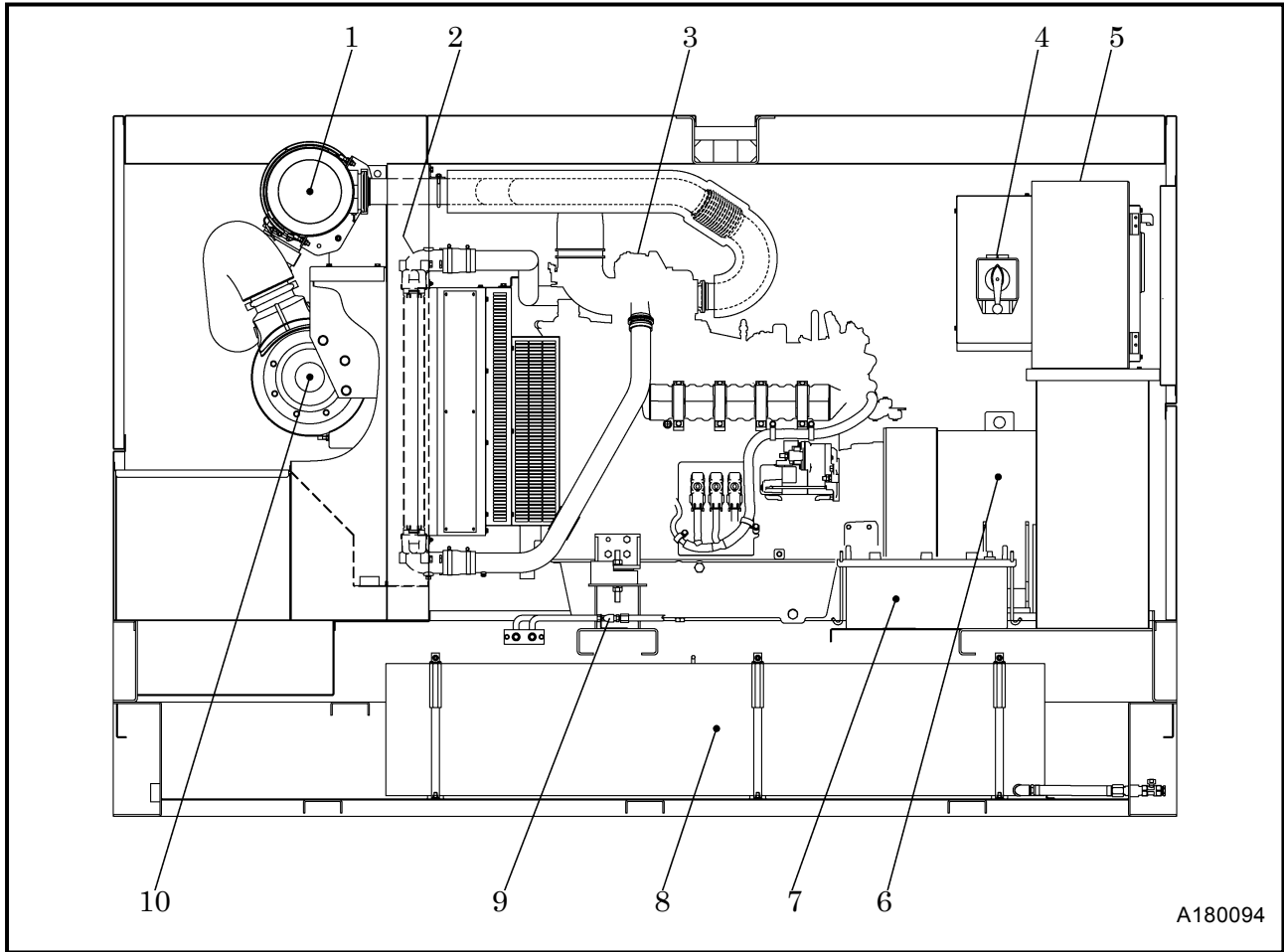

A180094

No.	Description	Function
1	DOC (Diesel Oxidation Catalyst)	Catalyst for oxidizing exhaust gas.
2	Intercooler	For cooling the air compressed by engine supercharger.
3	Engine	For driving the generator.
4	Voltage Selector Switch	For switching output voltage.
5	Control Panel	For controlling device; various meters and controls.
6	Generator	For generating AC power to be supplied.
7	Battery	For electrically starting engine.
8	Fuel Tank	For storing fuel.
9	Fuel Pipe Selector Valve	For switching to supply fuel from outer tank.
10	SCR (Selective Catalytic Reduction)	Selective reduction-type catalyst that uses DEF as a reducing agent.

1. Part Names

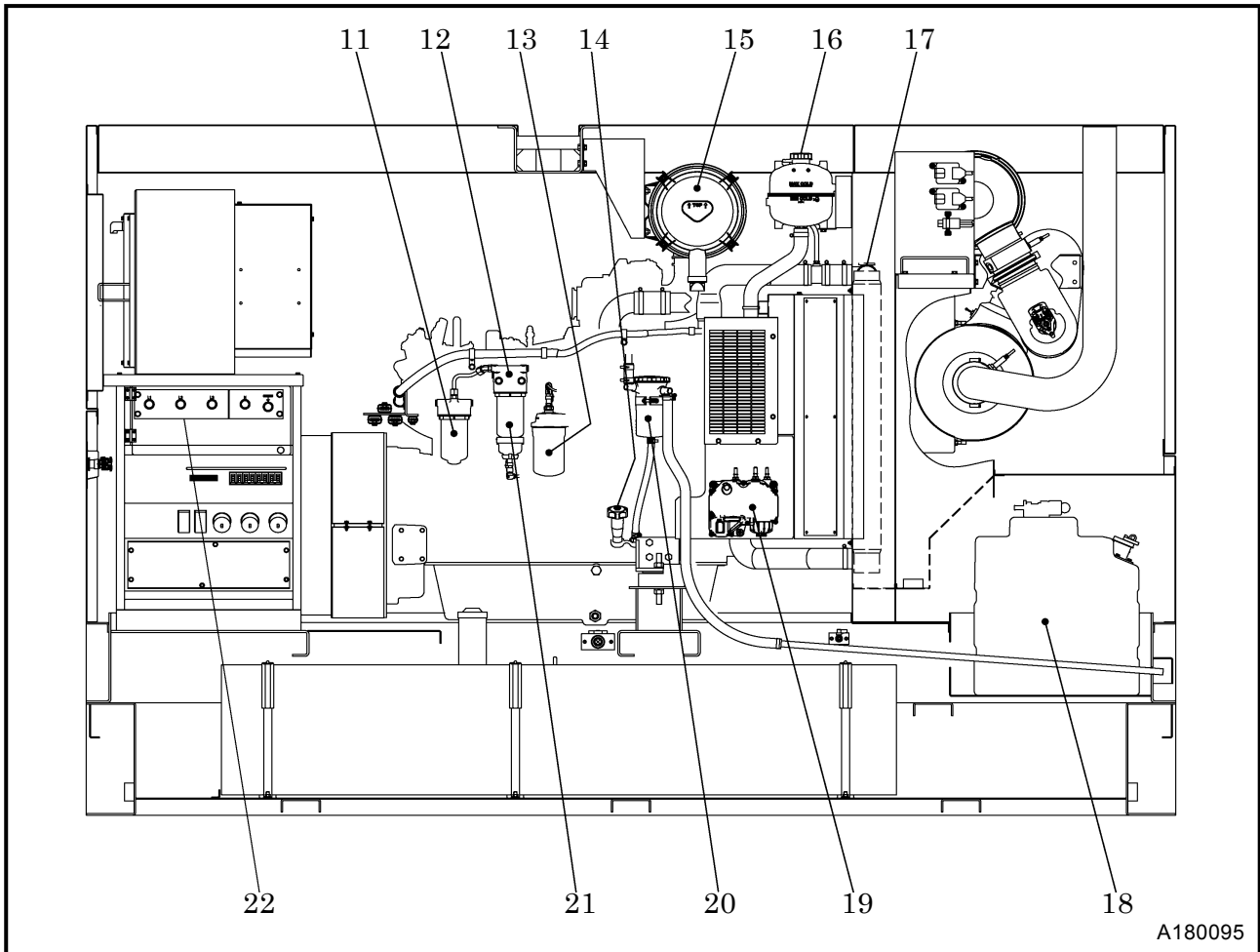

No.	Description	Function
11	Fuel Filter	For filtering foreign matter and dust mixed in fuel.
12	Fuel Air-Bleeding Pump	For automatically bleeding air from fuel pipes.
13	Engine oil filter	For filtering engine oil in the system.
14	Engine oil filler port (Oil Level Gauge)	For supplying and replenishing engine oil to engine. (Also for checking the engine oil level and contamination)
15	Air Filter	Filtering device for filtering dust floating in intake air.
16	Surge Tank	For checking coolant level and supplying it.
17	Radiator	For cooling the coolant for engine in the system.
18	DEF Tank	Container for DEF
19	DEF Supply Module	Pump unit for supplying DEF
20	OCV (Open Crankcase Ventilation) filter (Breather filter)	Device for filtering gas leaked from the engine combustion chamber.
21	Fuel Pre-Filter	For removing dust and water mixed in fuel.
22	Output Terminals	Outlet port for AC power.

2. Installation

NOTE: For trailer-mounted machines that are not installed, do not use this section. Refer to Addendum A – Transporting and Setup.

2.1 Transporting Machine

- When loading and unloading machine, be sure to use the lifting bail provided in the center of the machine top

2.1.1 Lifting

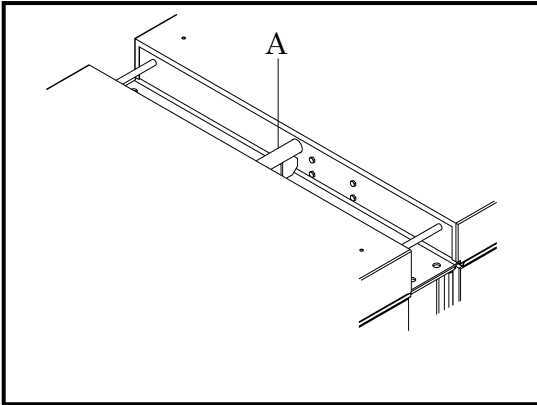

<Procedure>

1. Before lifting the machine up, make sure to check the lifting bail [A] for any cracks or loosened bolts.
 2. Connect the hook of the crane or shackle with lifting bail fitted at the top center of the machine, and make sure that there is no person standing around the machine. Then perform hoisting operation.
- Select an appropriate crane or truck by referring to the mass and dimensions mentioned in Chapter 7 “Specifications.”
 - Only a qualified crane operator is allowed to operate a crane.

2.1.2 Securing a machine on truck bed when transporting

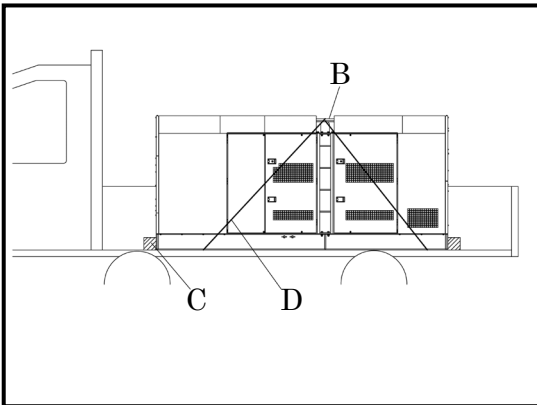

- When transporting the machine from construction site, be sure to load it into truck bed and secure it with rope [D] using rope hooks [B] on each side of bonnet and place blocks [C] on truck bed.

Transportation

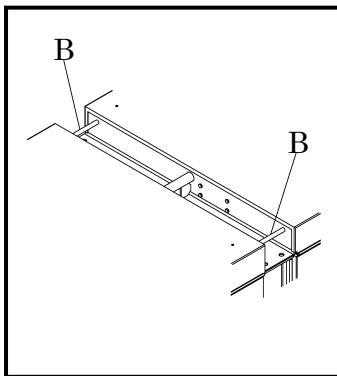

- Never go underneath the unit when suspended; it is very dangerous.
- When transporting the machine, be sure to put it on the truck bed and use the rope hooks [B] to secure it with rope.
- Do not lift machine while it is running; a fatal trouble or serious accident may occur.

2. Installation

2.2 Conditions of Machine Installation

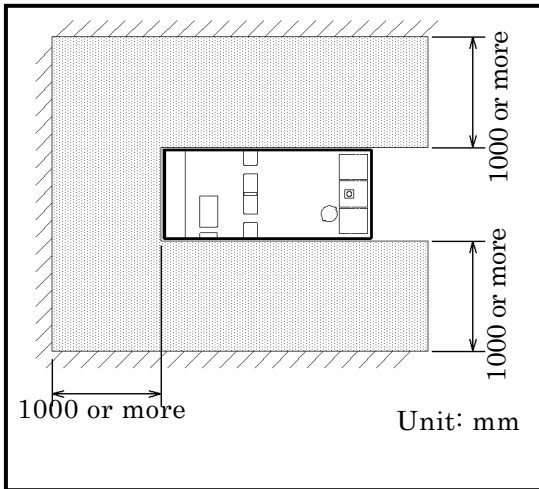

The machine has to be installed on dry, firm, and level area.

- The machine should be operated in following conditions:
 - Ambient temperature: - 5 °F to 104 °F (-15°C to +40°C)
 - Humidity ----- Less than 85%
 - Altitude ----- Lower than 1,000m above sea level
- ✘ If you use the machine not in the conditions stated above, it may cause serious breakdown.
- If more than two machines are placed parallel in operation, keep enough distance so that exhaust air from one machine does not affect the other one.
- Keep enough space around the machine for inspection and maintenance access.

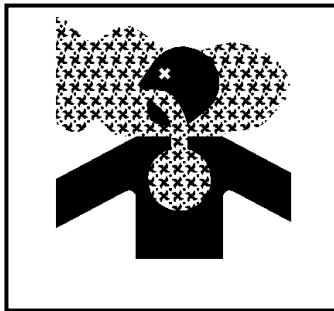

- Exhaust gas from the engine is poisonous and could cause casualties if inhaled. Avoid using the machine in an insufficiently ventilated building or a tunnel.
- Do not position the exhaust gas outlet in direction of a person or a house.

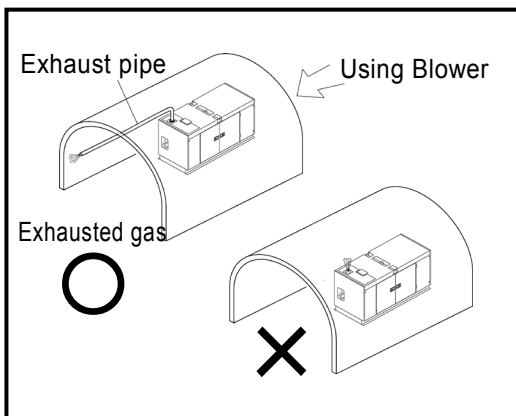

- In case that the machine is installed inside any tunnel, make sure to provide fresh air and ventilate it.
- In this case, make sure to extend the exhaust fume pipe outdoors, and also make sure to prevent any leak from any connection pipes.

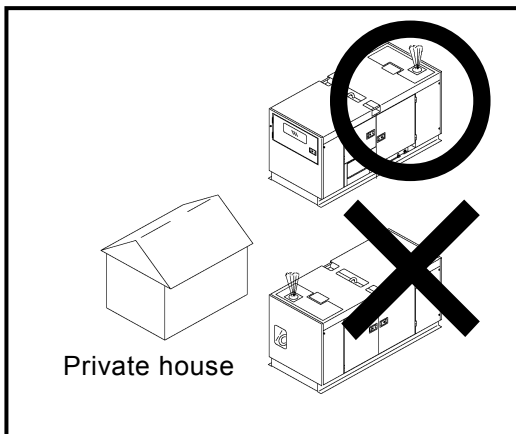

- Never locate the machine with the exhaust muffler facing any private house.
- The exhausted gas from the engine is poisonous; never direct it to any other persons passing by.

2. Installation

In case that the machine is installed indoors

WARNING

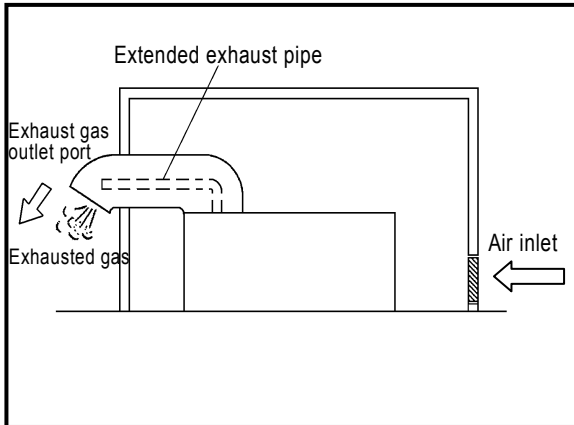

- In case that the machine is installed indoors for operation, suction air port and exhaust gas outlet port should be provided for better air ventilation.
- Make sure to secure enough space in front of air suction port and to secure it after exhaust gas outlet port so that the engine will not get overheated.
- An exhaust pipe or the like should be provided at the exhaust outlet port so as to send exhaust fumes outdoors.
- The cooling air outlet port of radiator should have access to the outdoors through a duct or the like for air ventilation.

CAUTION

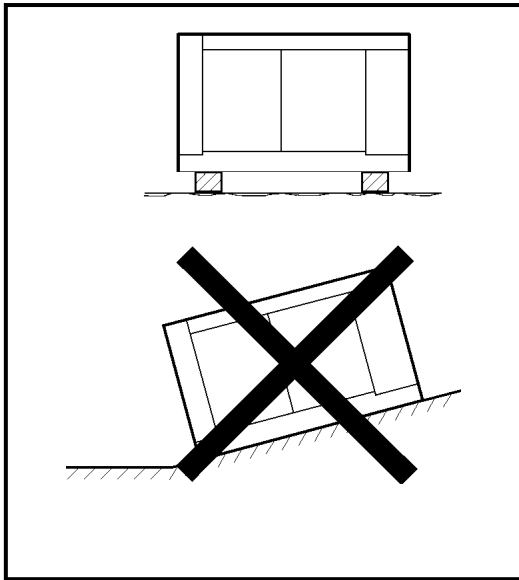

- The machine should be installed within 5° degree inclination.
- If installation site is not flat, put square bar under the machine in order to install it horizontally.
- Avoid installing the unit in a damp place or a place where water collects. Such an installation could cause electric shock.
- When installing the unit at the sea shore or on a ship, make sure that it is not exposed directly to sea water because there is a risk of the change to the insulation resistance of the generator assembly or control panel inside. To request a model with measures against salt damage, please consult the nearest sales office.
- When installing the machine in a sandy place, make sure that exhaust from the generator or radiator does not blow the sand up in the air, or into the machine.

Safety fence

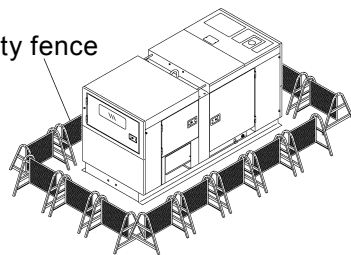

- In order to prevent any persons other than those engaged in the job site from using or interacting with the machine, please prepare for safety fences around the unit.

2. Installation

2.3 Grounding Procedure

2.3.1 Ground terminal

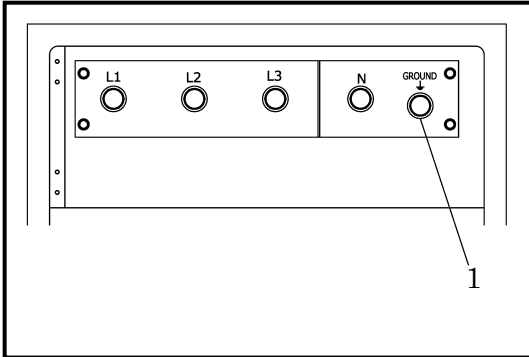

- The ground terminal [1] on the AC output terminal board is connected to the earth ground of this unit and to the earth terminal of each outlet

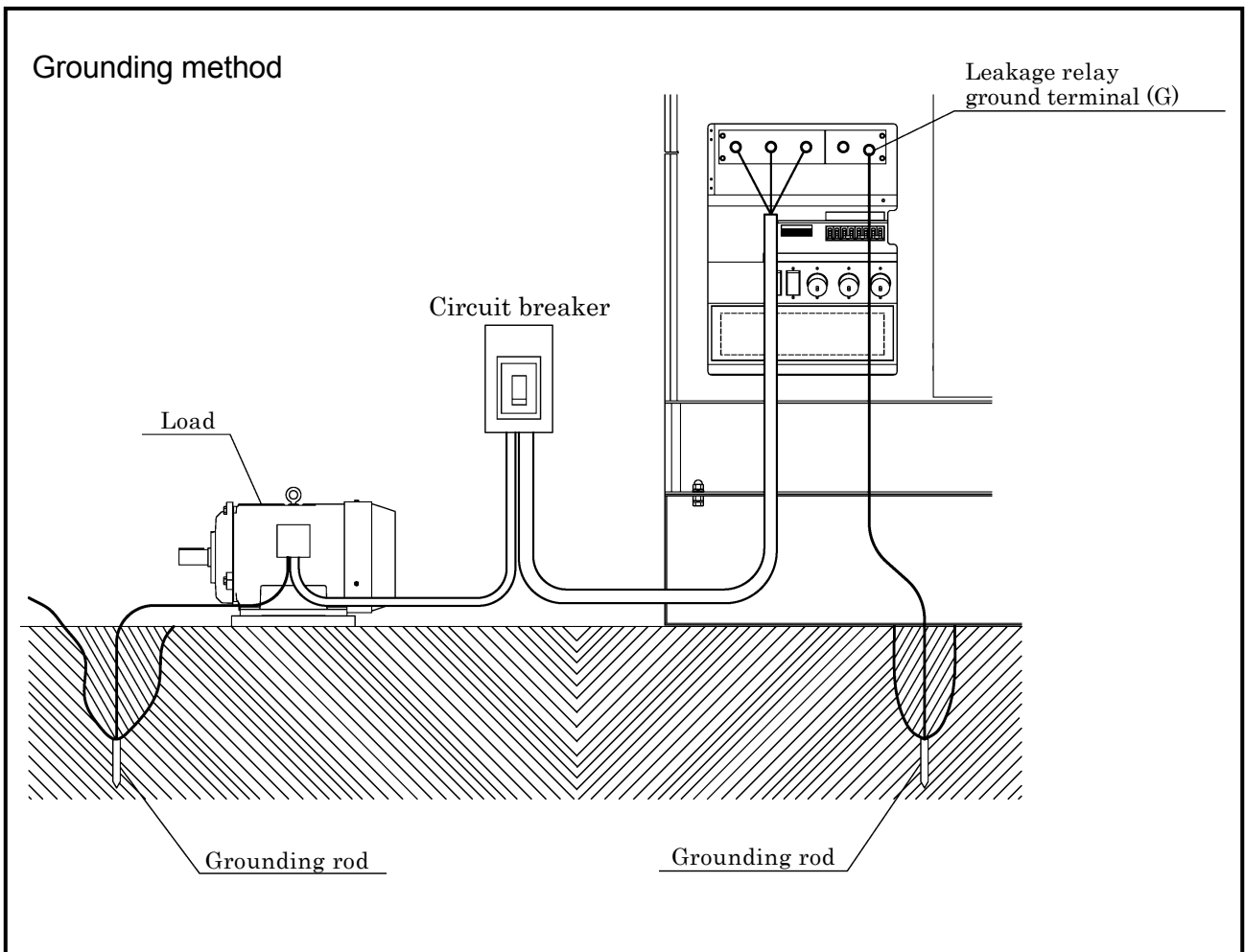

2.3.2 Ground system

The generators have a system ground that connects generator frame components to the ground terminals in the AC output receptacles. The AC neutral wire is connected to the system ground.

2. Installation

2.3.3 GFCI (Ground-fault circuit interrupter) Receptacles

- All of the 20 ampere 120 volt receptacles on the generator are protected by a GFCI (Ground-fault circuit interrupter) for protection against the hazards of ground fault currents. An example of ground-fault current is the current which would flow through a person who is using an appliance with faulty insulation and, at the same time, is in contact with an electrical ground such as a plumbing fixture, wet floor, or earth.
- The ground-fault circuit interrupter will not protect against short circuits or overloads. The circuit breaker in the control panel which supplies power to the circuit provides that protection.
- The ground-fault circuit interrupter can be identified by the TEST and RESET buttons. The receptacles on the GFCI can be tested with the TEST and RESET buttons.

TEST BUTTON: To test, depress the "TEST" button. (power is turned off)

RESET BUTTON: To restore power, depress the "RESET" button.

- Perform this test monthly or every 250 hours operation whichever comes first, in order to ensure proper operation of the GFCI receptacle. If the generator is stored outdoors, unprotected from the weather, test the GFCI receptacle before each use. Record your test on the GFCI test card provided on the control panel.

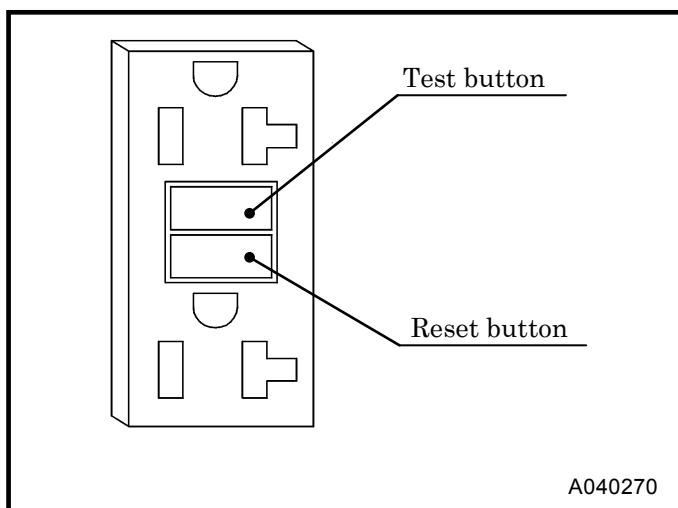

- Using the generator in rain, snow, or near water can lead to death from electric shock. Keep the generator dry.

2. Installation

2.3.4 Connections to a building's electrical system

- Connections for standby power to a building's electrical system must be made by a qualified electrician. The connection must isolate the generator power from utility power, and must comply with all applicable laws and electrical codes.



- Improper connections to a building's electrical system can allow electrical current from the generator to backfeed into the utility lines. Such backfeed may electrocute utility company workers or others who are in contact with the lines during a power outage. Consult the utility company or a qualified electrician.
- Improper connections to a building's electrical system can allow electrical current from the utility company to backfeed into the generator. When utility power is restored, the generator may explode, burn, or cause a fire in the building's electrical system.

2. Installation

2.4 Selecting Cable

- Select a cable with sufficient diameter by considering the permissible current on the cable and the distance from the machine to the load.
- If the current flowing to the load exceeds the permissible current of the cable, resultant overheating may burn the cable. Similarly, if the cable is too small in thickness compared to the length, the input voltage to the load will fall. As a result, the performance of the machine cannot be displayed.

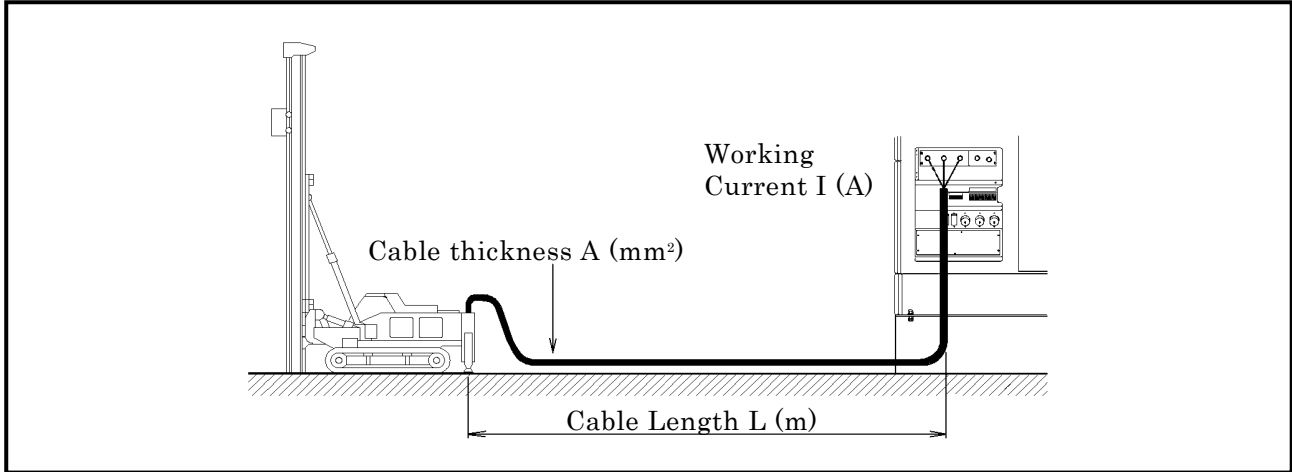

- Simplified three-phase three-wire formula to seek voltage drop or cross-sectional area of the cable from cable length and working current. Select such a cable length and thickness so that the voltage drop will remain less than 5%.

Output System	Voltage Drop	Cross-sectional area of Cable	e : Voltage drop(V) e' : Voltage drop between outside line or one line of each phase and neutral line. A: Cable thickness (mm²) L: Cable length (m) I: Working current (A)
3 Phase,3 Wire	$e = \frac{30.8 \times L \times I}{1,000 \times A}$	$A = \frac{30.8 \times L \times I}{1,000 \times e}$	
3 Phase,4 Wire	$e' = \frac{17.8 \times L \times I}{1,000 \times A}$	$A = \frac{17.8 \times L \times I}{1,000 \times e'}$	

- The following tables show the relations between the cable length and the cable thickness (nominal cross-sectional area) suited to the working current. (Based on the condition that working voltage is 200V, with voltage drop of 10V.)

Single-Conductor Cabtyre Cable

Unit:mm²

Current \ Length	165ft(50m)	246ft(75m)	328ft(100m)	410ft(125m)	492ft(150m)	656ft(200m)
150A	38	38	50	60	80	100
200A	60	60	60	80	100	125
300A	100	100	100	125	150	200
400A	125	150	150	200	200	250

Three-Conductor Cabtyre Cable

Unit:mm²

Current \ Length	165ft(50m)	246ft(75m)	328ft(100m)	410ft(125m)	492ft(150m)	656ft(200m)
150A	22×2	22×2	38×2	38×2	50×2	50×2
200A	38×2	38×2	50×2	50×2	50×2	60×2
300A	60×2	60×2	60×2	60×2	80×2	100×2
400A	60×2	60×2	60×2	80×2	100×2	125×2

2. Installation

2.5 Fuel Pipe Selector Valve

2.5.1 Selector valve

This valve is designed to feed fuel directly from an external fuel tank or from the installed fuel tank as described below.

2.5.2 Operation method

<Procedure>

1. Machine is delivered from factory with fuel line piping and selector valves built in as shown in the following Fig.1. When operating a machine, using installed fuel tank, run the machine with the fuel line piping and the handles of selector valves factory-arranged.
2. When using a separate storage tank, remove the plug fitted at the connections to the separator tank and make piping as shown in Fig.2. And then turn the handles of the selector valve as shown in Fig.2.
3. When removing the piping connections, make sure to return the handles to the original positions shown in Fig.1 and install the plugs.

2.5.3 Installation of Separate Storage Fuel tank and piping method

<Procedure>

1. Use oil resistant hoses of inside diameter of 8mm to 10mm.
2. Install the fuel tank so that the fuel level of the tank may be kept at the level from 0 to 2.5m high from the machine installation level.
3. In order to avoid suction of water and sediment together, install the suction pipe so that the inlet port of suction pipe may be kept at the 15mm to 20mm higher level than the bottom line of the tank. Also install the outlet port of the return pipe inside the tank. (See A, Fig. 2)
4. When refilling fuel in the tank, take much care not mix water and sediment.

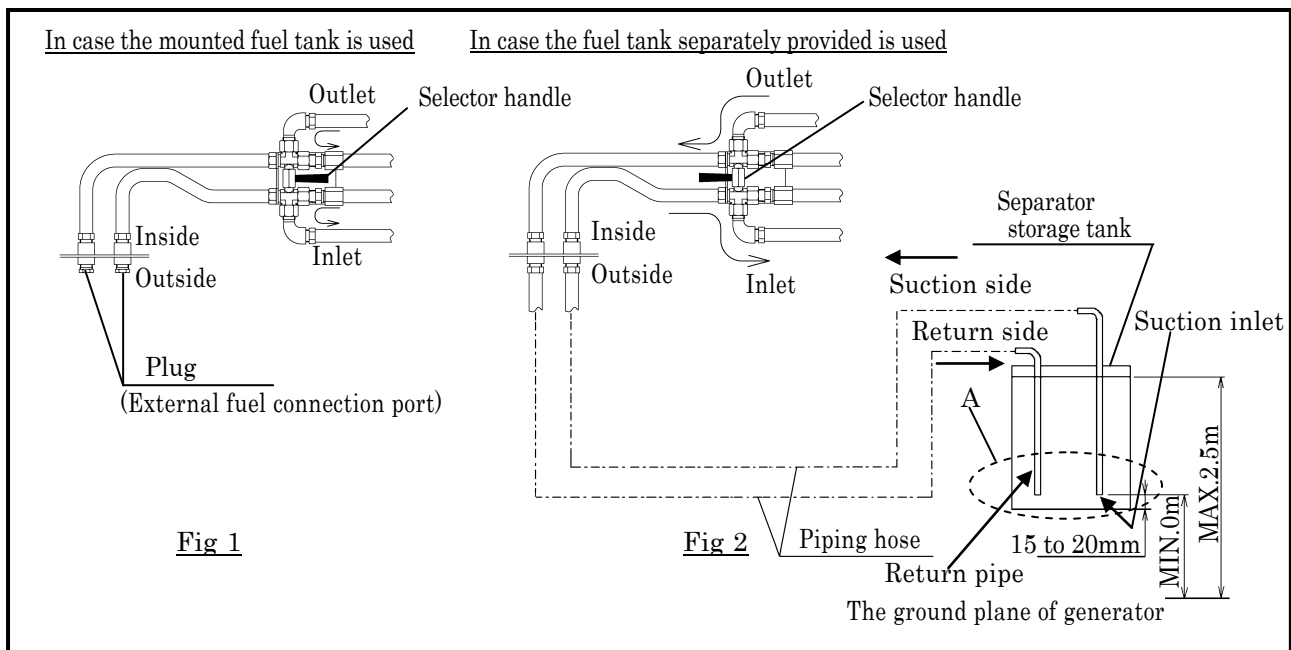

- Monitor the fuel feeding conditions while feeding fuel from the external fuel storage tank.
- When using an external fuel tank, take care to ensure that the DEF tank is also refilled as needed.
- Make sure to change the handles of the selector valves to a predetermined position. If you make a mistake in turning the handles, it can burst the fuel pipe and cause overflowing, possibly leading to a serious accident.
- Do not use excessive force on the selector valve handle; it could cause damage or fuel leakage.
- When using the external fuel tank, the Fuel Level displayed on the monitor will not provide an accurate measurement.

3. Operation

3.1 Instrument panel

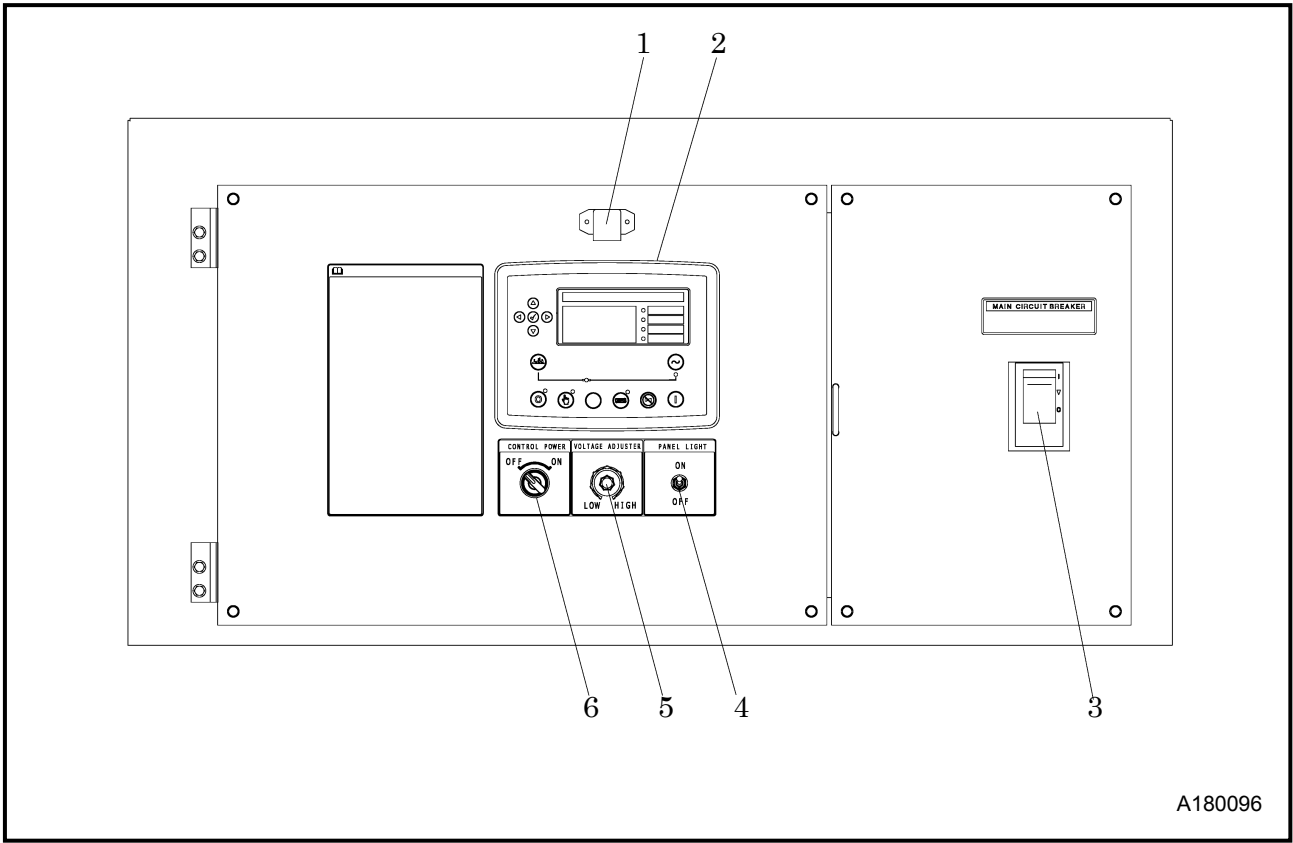

A180096

1. Panel Light

2. Control panel

3. Circuit Breaker

4. Panel Light Switch

5. Voltage Regulator

6. Control Power Switch

3. Operation

Control panel

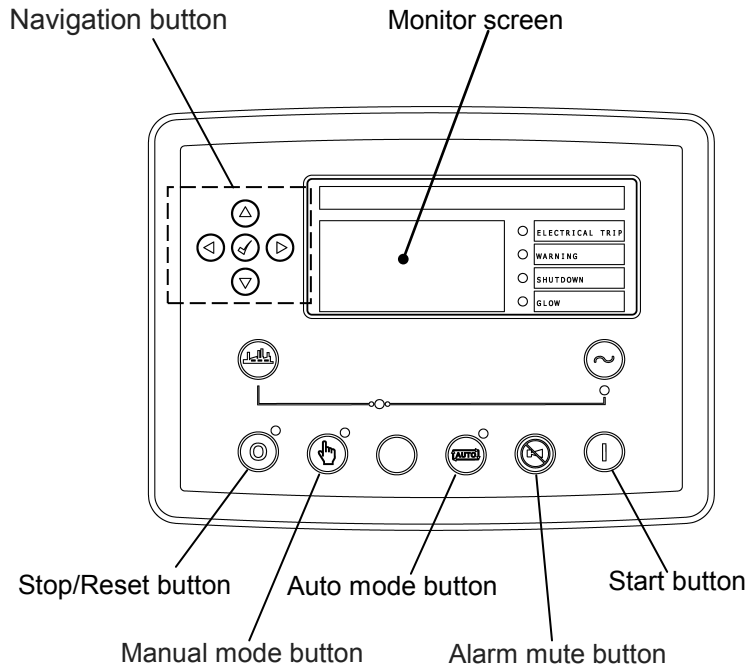

A180097E

[How to switch monitor]

1. Items shown below can be selected by pressing ◀ or ▶ button.

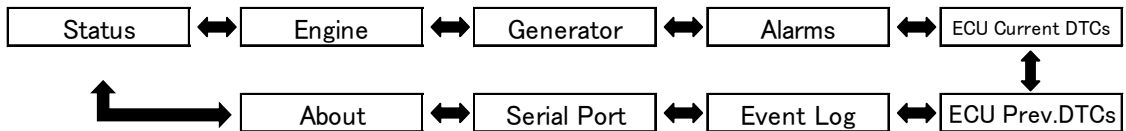

2. Parameters within an item can be viewed by pressing ▲ and ▼ button.

3. Monitor will return to main screen if no commands are entered for 3 minutes.



Main screen

3. Operation

3.2 Connecting Loads

Select a cable with sufficient diameter by considering the load capacity and the distance from the generator to the load. Use terminals for connection and securely fasten them. (See Section 2.4)

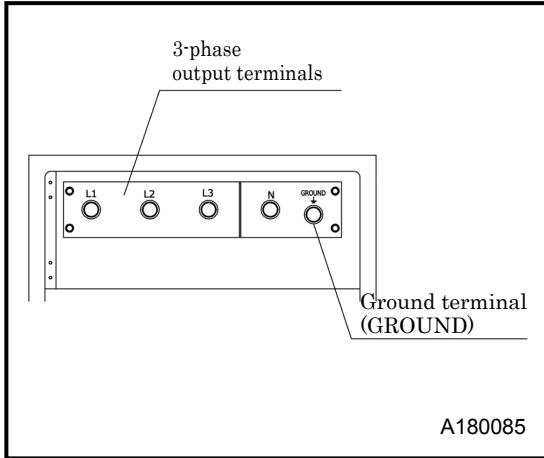

- After checking phase number and voltage of the load, make sure to connect them correctly.

— Terminal size —

Three-phase output (L1, L2, L3, N)	M14
Leakage relay ground terminal (G)	M14

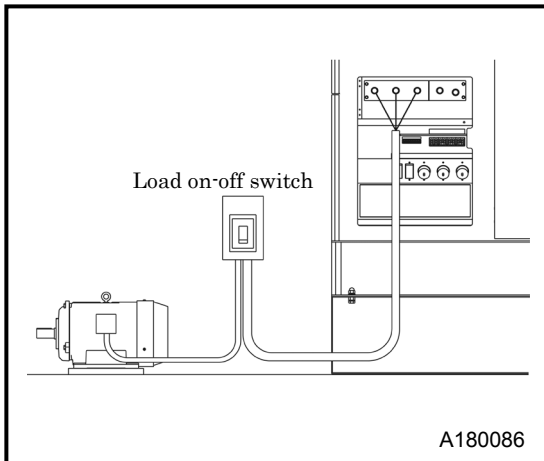

- Install a switch between the output terminal and the load to switch on/off the load. Do not switch the load on/off directly by the circuit-breaker of the generator. It could cause damage to the circuit-breaker.
- Connect the connecting cable to the load so that the output terminals should not touch each other.

WARNING





W013

- When removing or connecting a connecting cable for changing load, be sure to switch OFF the circuit breaker, remove the starter key from the starter switch, then carry out the work. The operator must keep the key during operation.
- For a connecting cable to load, do not use a cable with damaged sheath nor an inappropriate insulation cable to the voltage. Secure connections between each cable terminal and input/output terminal. Otherwise, it may be slacked during operation and may cause a fire or an electric shock accident.

3. Operation

3.2.1 Output Terminal connections

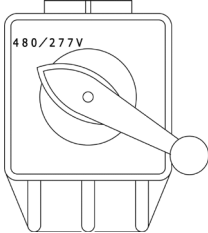
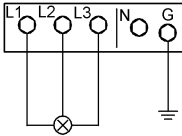
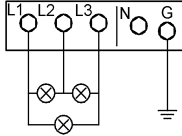
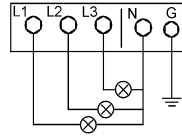
<p>Voltage selector SW. Three-phase 480/277V</p>	<p>Output terminals Three-phase 480V</p>	<p>Output terminals Single-phase 480V</p>	<p>Output terminals Single-phase 277V</p>
			
A180081	A040153-1	A040154-1	A040155-1

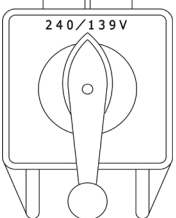
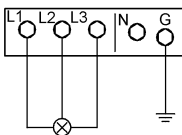
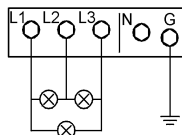
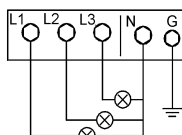
<p>Voltage selector SW. Three-phase 240/139V</p>	<p>Output terminals Three-phase 240V</p>	<p>Output terminals Single-phase 240V</p>	<p>Output terminals Single-phase 139V</p>
			
A180082	A040156-1	A040157-1	A040158-1

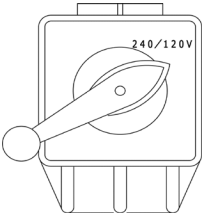
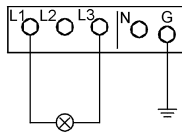
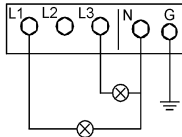
<p>Voltage selector SW. Single-phase 240/120V</p>	<p>Output terminals Single-phase 240V</p>	<p>Output terminals Single-phase 120V</p>
		
A180083	A040159-11	A040160-1

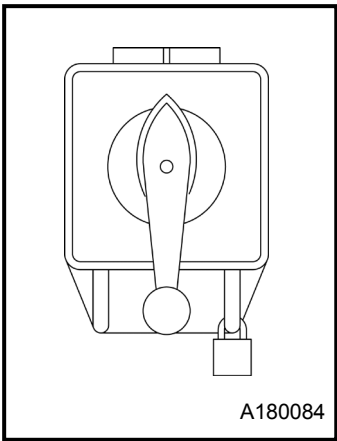
	 <p>A180084</p>	<ul style="list-style-type: none"> ● During operation, do not operate the voltage selector switch. Voltage selection during operation may cause abnormal voltage on the load side to damage the load and may cause a fire. ● Operating the voltage selector switch during operation may cause damage to the generator body and the automatic voltage regulator (AVR). ● Be sure to shut off the generator before using the voltage selector switch. ● When voltage selection is completed, lock the voltage selector switch in position to prevent anyone from operating it.
---	--	--

3. Operation

3.2.2 Auxiliary AC Power

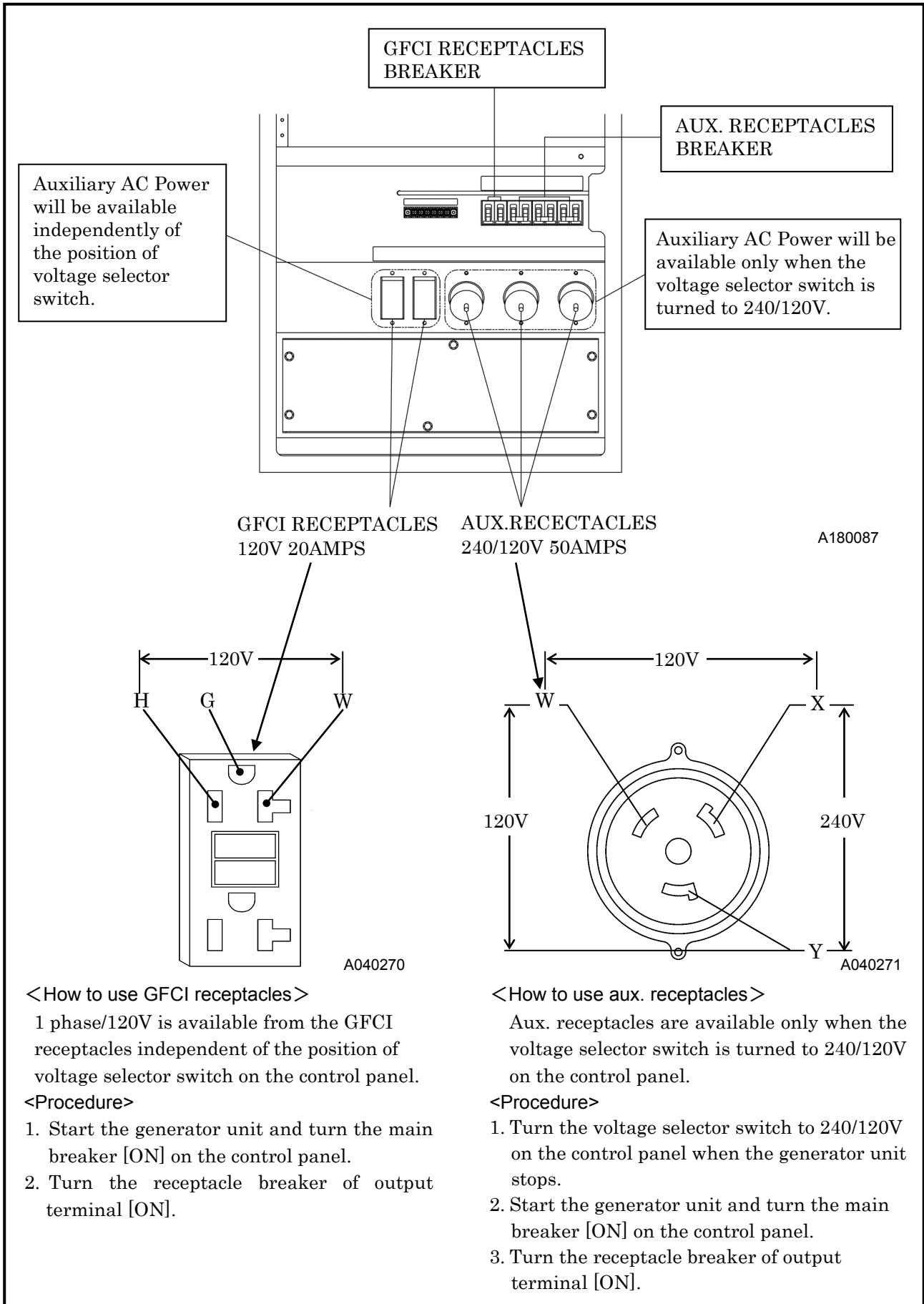

3. Operation

3.2.3 Load Capacity of the GFCI Outlet

The tables below show the allowable load capacity of the GFCI outlet (single-phase 120V) when either single-phase (240/120V) or three-phase (240/480V) from the main terminal is used. (The current value is per GFCI outlet.)

[Allowable load capacity of the GFCI outlet when single-phase is used]

Single-phase (240/120V)	GFCI outlet (single-phase 120V)
kW	A
87.0	0
85.8	5
84.6	10
83.4	15
82.2	20

[Allowable load capacity of the GFCI outlet when three-phase is used]

Three-phase (240/480V)	GFCI outlet (single-phase 120V)
kVA	A
150	0
146	5
142	10
138	15
133	20



- When the main terminal, single-phase (240/120V) or three-phase (240/480V) is used together with the GFCI outlet (single-phase 120V), the above allowable load capacity of the GFCI outlet must not be exceeded.

3. Operation

3.3 Engine Oil • Coolant • Fuel • DEF

3.3.1 Engine Oil

Use engine oil recommended by us. Be sure to use CJ class or higher engine oil. (Using engine oil with poor quality may shorten the life of the engine).

Classification	API service classification CJ class or higher
Viscosity	SAE15W-40

IMPORTANT

- Viscosity of engine oil greatly affects starting, performance, and oil consumption of the engine, as well as wear of the moving parts. Choose appropriate oil based upon the table below according to the outside air temperature.

Ambient temperature range and oil viscosity (SAE)

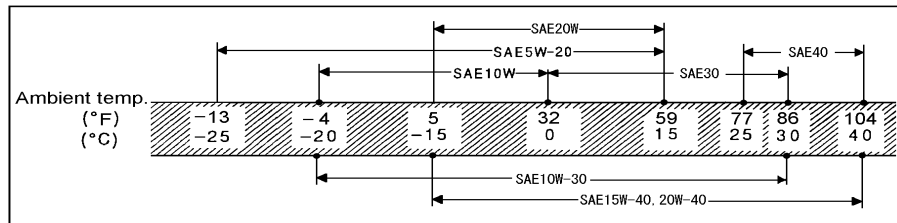

A180160E

- When two or more different brands of oil are mixed, its performance can be deteriorated. Do not mix oils.
- When it is expected to be used for a long period at light load (less than 20% load), it is better to replace the oil with suitable oil.
- John Deere Plus-50™ II is the recommended oil for this engine
- **Follow the designated regulations to dispose of engine oil.**

3.3.2 Coolant

Coolant freezing could cause cracks in cylinder and radiator. Be sure to always use mixture of LLC (antifreeze solution) and soft water (like tap water) of good quality.

IMPORTANT

- When water with dirt, sand, or dust, or hard water such as well water (ground water) is used, deposits can form inside the radiator or on the cylinder head and resulting in engine overheating from poor coolant flow.
- Adjust mixing ratio of LLC (antifreeze) with water according to the temperature. (When the machine is delivered from factory, it is filled with a 35% density oil.) Use LLC (antifreeze) within the range of its mixing ratio between 30 and 60%. (If LLC (antifreeze) in the water exceeds more than 60%, it may decrease its effectiveness.)

Mixing ratio of LLC (antifreeze) (reference)

Outside temperature (°F)	5	-4	-13	-22	-31	-40	-49
Outside temperature (°C)	-15	-20	-25	-30	-35	-40	-45
Mixing ratio (%)	30	35	40	45	50	55	60

- **Follow the designated regulations to dispose of LLC (Antifreeze).**

3. Operation

3.3.3 Fuel

	<ul style="list-style-type: none">● Never use fuel with sulfur content greater 0.0010% (10ppm)● Use only ultra-low sulfur fuel.● Dispose of fuel in accordance with all applicable regulations.
---	--

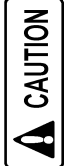
	<ul style="list-style-type: none">● Diesel fuel is required to meet the following conditions.<ul style="list-style-type: none">● Free from even minute dust particles.● High optimum viscosity.● High cetane number.● High fluidity even at low temperature.● Low carbon residue content.
---	---

3.3.4 DEF

DEF (AdBlue or equivalent) is transparent, colorless, and non-hazardous. In some circumstances, DEF will put off odor, but this is normal and not indicative of any problems.

	<ul style="list-style-type: none">● Only use DEF which conforms to API standards.● Store DEF in a sealed container away from direct sunlight to prevent water evaporation.● The usable period of DEF depends on temperature. For details, reference the engine manual.● If a substantial quantity of DEF is not within specification, contact the DEF supplier for assistance with disposal. Do not dump substantial quantities of DEF onto the ground or send DEF to wastewater treatment facilities.
---	---

	<ul style="list-style-type: none">● Avoid contact with eyes. In case of contact, immediately flush eyes with large amounts of water for a minimum of 15 minutes.<ul style="list-style-type: none">● Do not ingest DEF. In the event that DEF is ingested, contact a physician immediately.● Avoid prolonged contact with skin. In case of accidental contact, wash skin immediately with soap and water.● Reference the Materials Safety Data Sheet (MSDS) for additional information.
---	--

3. Operation

3.4 Before Starting the Unit

Be sure to check the unit before operation. When any abnormality is found, be sure to repair it before starting. Be sure to perform daily checks before operation. If the unit is operated without performing these checks, unnoticed abnormalities could cause seizure of components and may even cause fire.

3.4.1 Check Engine Oil Level

The unit should be on a level surface before checking oil level. If you check oil level after you have started operation, wait 10 to 20 minutes after stopping the engine before checking the oil level.

<Procedures>

1. Pull out the engine oil level dipstick and wipe it with a clean cloth.
 2. Re-insert the dipstick fully and pull it out again. If the gauge shows the oil level between ADD and FULL limits, it is normal.
 3. When the oil level is below its ADD, add engine oil from engine oil filler port [A].
- While checking oil level, check also for contamination.
If the oil is found to be dirty or contaminated change the oil. (See Section 5.4.1)
 - To prevent engine output reduction when oil level is too high, do not put more oil in than the upper limit (FULL).

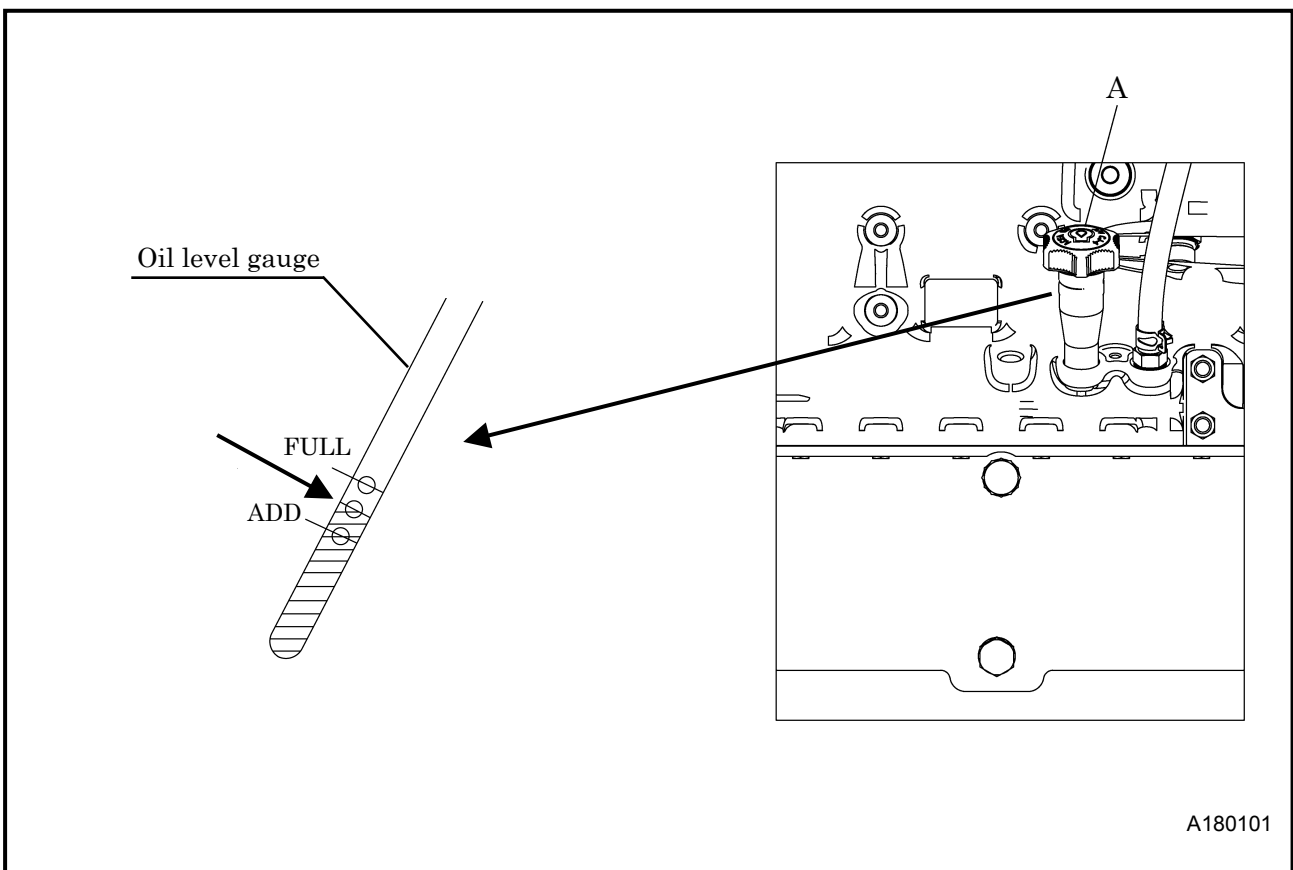

3. Operation

3.4.2 Check Coolant Level

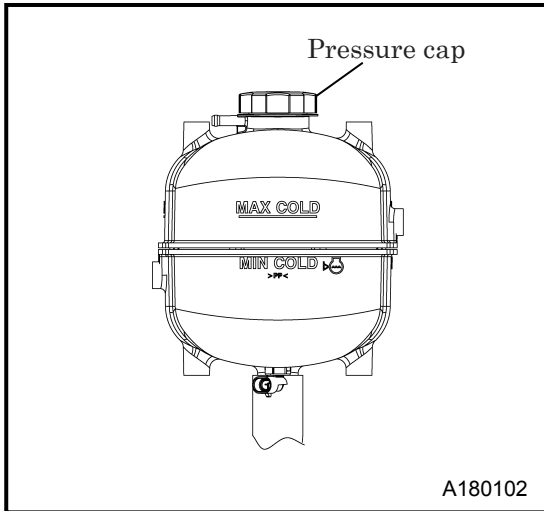

- Check the coolant level in the surge tank. If it is lower than the limit, open the pressure cap and replenish the coolant.
(Level must be kept above MIN COLD mark.)

IMPORTANT

- Do not operate the machine without sufficient coolant. Insufficient coolant can cause air bubbles to form and damage the radiator.

3.4.3 Check Fuel

Before starting operation, make sure to check the level of residual fuel so that fuel shortage during operation can be avoided.

If necessary, drain condensate accumulated at the bottom of the fuel tank.

- Refilling fuel tank should be done in an outdoor well-ventilated place.
- **Do not fill fuel oil up to the filler level. When fuel tank is filled up to the filler level, the expansion volume of the tank is too small and could lead to problems with fuel flow and containment. Furthermore, fuel may spill from the fuel tank due to vibration caused during movement or transportation of machine.**

CAUTION



- Do not, under any circumstance, bring lit cigarettes and/or matches to the fuel.
- The fuel is extremely flammable and dangerous. Be careful of fire as the fuel is very likely to catch fire.
- Refuel only after stopping the engine, and never leave open fuel can near the machine. Do not spill; it could cause a fire. If fuel is spilt, wipe it up completely.
- Never use alcohol-base cleaning fluid. Prolonged contact with some parts may it cause degradation of liquid surface visibility and, in the worst case, can lead to cracking and result in fuel leaks.

3. Operation

3.4.4 Check Fuel Pre-Filter Drain

Warning lamp will illuminate when water is accumulated inside the fuel pre-filter. Drain water from the fuel pre-filter when the warning occurs.

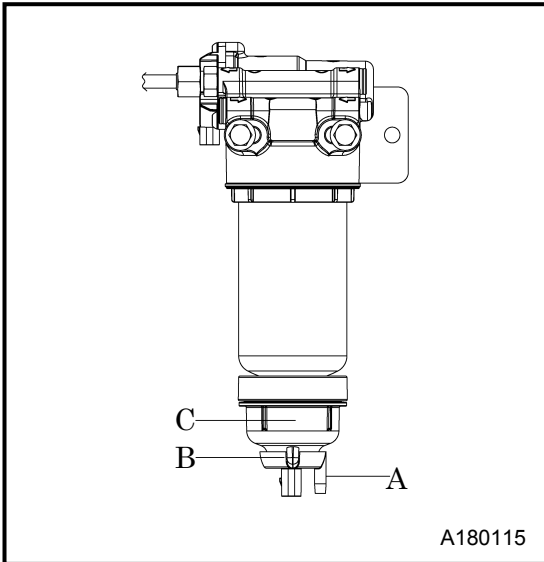

<Procedure>

1. When draining water, connect the hose to drain outlet [A].
2. Using a container to prevent spills, slide drainage lever [B] to drain the condensate from drain outlet [A].
 - Carefully remove the cup [C] so as to avoid spilling diesel oil inside the machine.
3. After draining the condensate (water) accumulated in the cup, cover the interior of cup in diesel oil and then re-install it.
4. Lastly, put drainage lever [B] back in the original position and disconnect the drain hose.
 - Dispose of condensate according to applicable regulations.

3.4.5 Check DEF Level

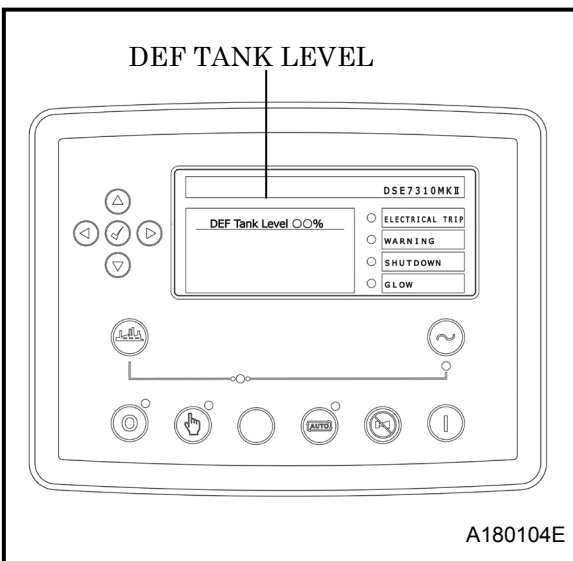

- If DEF tank level is below 10%, warning lamps will illuminate and symbols will be displayed as shown below.
- If DEF tank level is at 0% and the engine is operated with no DEF, the engine will shut down. If the engine stops in this condition, John Deere service software is required to restore operation.
 - ✘ When refilling diesel fuel, refill DEF as well.

DEF Tank level display

State Description	DEF Level	Over 10%	Below 10%	0%	Empty Or after 4h from 0%
Indicator	Icon (DEF Level)	–			
	ECU Amber Alarm	–			
	Warning lamp	–	●:ON	●:ON	●:ON
	Shutdown lamp	–	–	–	●:ON

3. Operation

3.4.6 Check Interior

Periodically check the inside of the generator for dust and flammables.

	<ul style="list-style-type: none">● Please wear protection implements, such as a helmet, protection glasses, earplugs, safety shoes, gloves, and a protection-against-dust mask, according to the contents of work for safety.● Periodically check the inside of the generator for dust and flammables. When any flammables such as chips of wood, dead leaves (dry leaves) and waste paper are left near heated exhaust muffler and heated exhaust pipe, all of them should be removed.● Keep a fire extinguisher available by the machine in case of unexpected fire.● It is advisable to have a list of phone numbers of doctors, ambulance and the fire department available in case of emergency.
---	---

3.4.7 Clean instruments in control panel

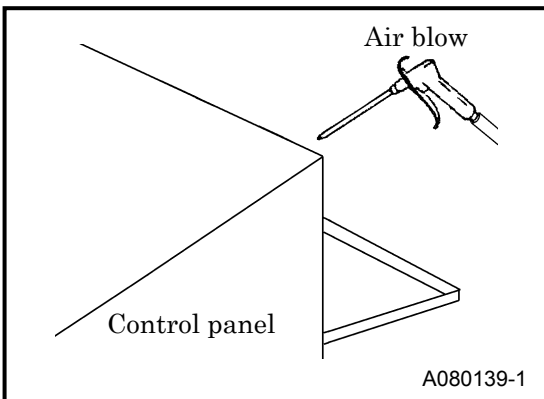

- Before starting operation, open control panel and check each breaker, terminal plate and each controller for any dust, sand and dirt accumulated.
- If the machine is operated with dust, sand, or dirt in the instrumentation, it could cause malfunction or damage. When necessary, clean the inside of the panel with compressed air. Wear protective eyewear when cleaning.

3.4.8 Check Belt Tension

Generally, it is not required to manually adjust belt tension because an auto tensioner is installed. Before starting the engine, visually inspect the belt for cracks or wear.

3.4.9 Check Thermo Label on the Stator

Thermo-label on the stator irreversibly changes its color from white to brown by reaching or exceeding 100°C, that signalize overload during operation. Do not overload the generator.

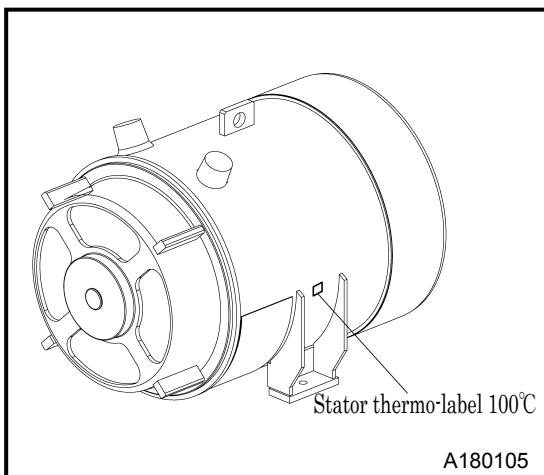

- Remove the trash and dust from the generator inside by compressed air blowing.
- Replace thermo-label, if it have changed the color once.
- When replacing, contact our office nearby or distributor.

3. Operation

3.4.10 Check Oil Fence Drain

There are two oil fence drains, one at the front and one at the rear.

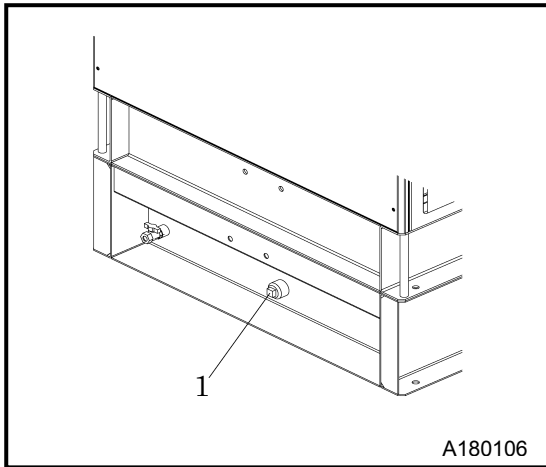

- Remove drain plug [1] from the oil fence drain to drain the condensate.
- Check that all condensate is drained, and then re-install the drain plug.
- Drain the condensate into a container and dispose of condensate according to applicable regulations.

3.4.11 Check Doors

Pull the handle forward to open the door.

Be sure to close the door tightly so that its latch is firmly caught.

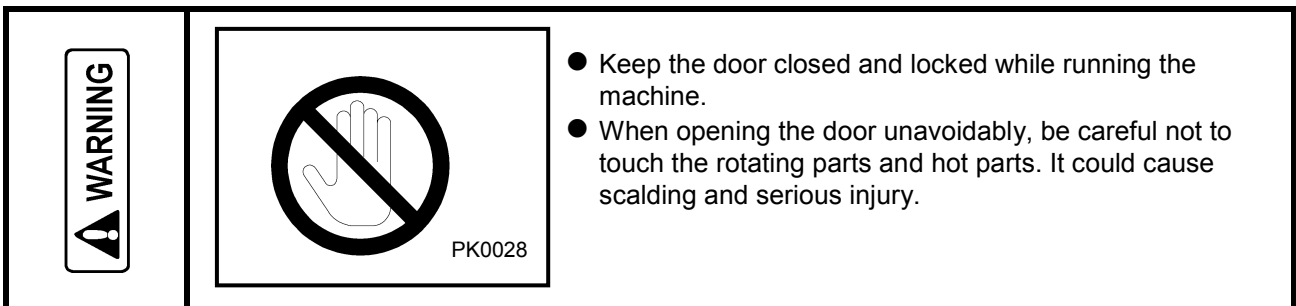

- Keep the door closed and locked while running the machine.
- When opening the door unavoidably, be careful not to touch the rotating parts and hot parts. It could cause scalding and serious injury.

3.4.12 Checking the Engine Breathing Pipe

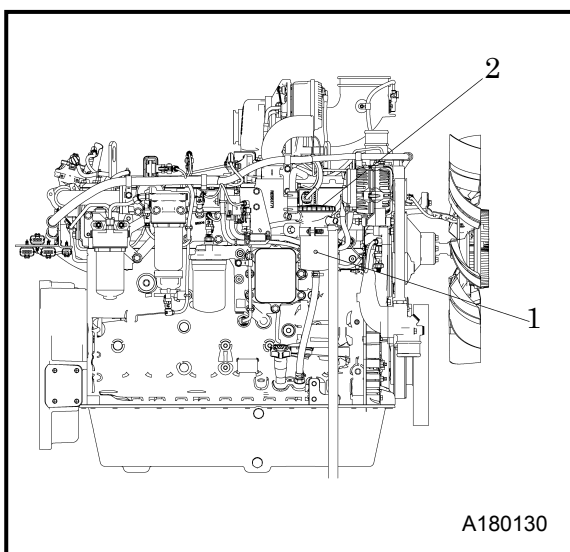

- Remove cap [2] of OVC filter [1] by rotating it counterclockwise. Remove the filter from the inside, and then check if the inside is clogged. If the inside is clogged, the thrust chamber pressure may rise, causing the engine oil to be released into the air from the hose installed in the engine head. Especially during cold weather operation, freezing in the breathing pipe may cause clogging of the filter. Check for water accumulation to prevent this.
- For details on replacing the OCV filter, see Section 5.4.18.

3. Operation

3.5 Operating Procedure

Make sure that all enclosure doors are closed before starting.

3.5.1 Procedure for starting and stopping

To start, please follow the procedure below.

<Manual Start Procedures>

1. Set the circuit breaker [A] on the instrument panel to [OFF] position.
2. Set the selector switch [B] to [ON] position.
3. Push the manual mode button [C].
4. Push the start button [D] to run the engine.
(During cold times, pre-heating starts automatically. After GLOW lamp [E] is switched off, the engine starts.)
5. Once engine has started, let it warm up approximately 5 minutes at no-load condition.

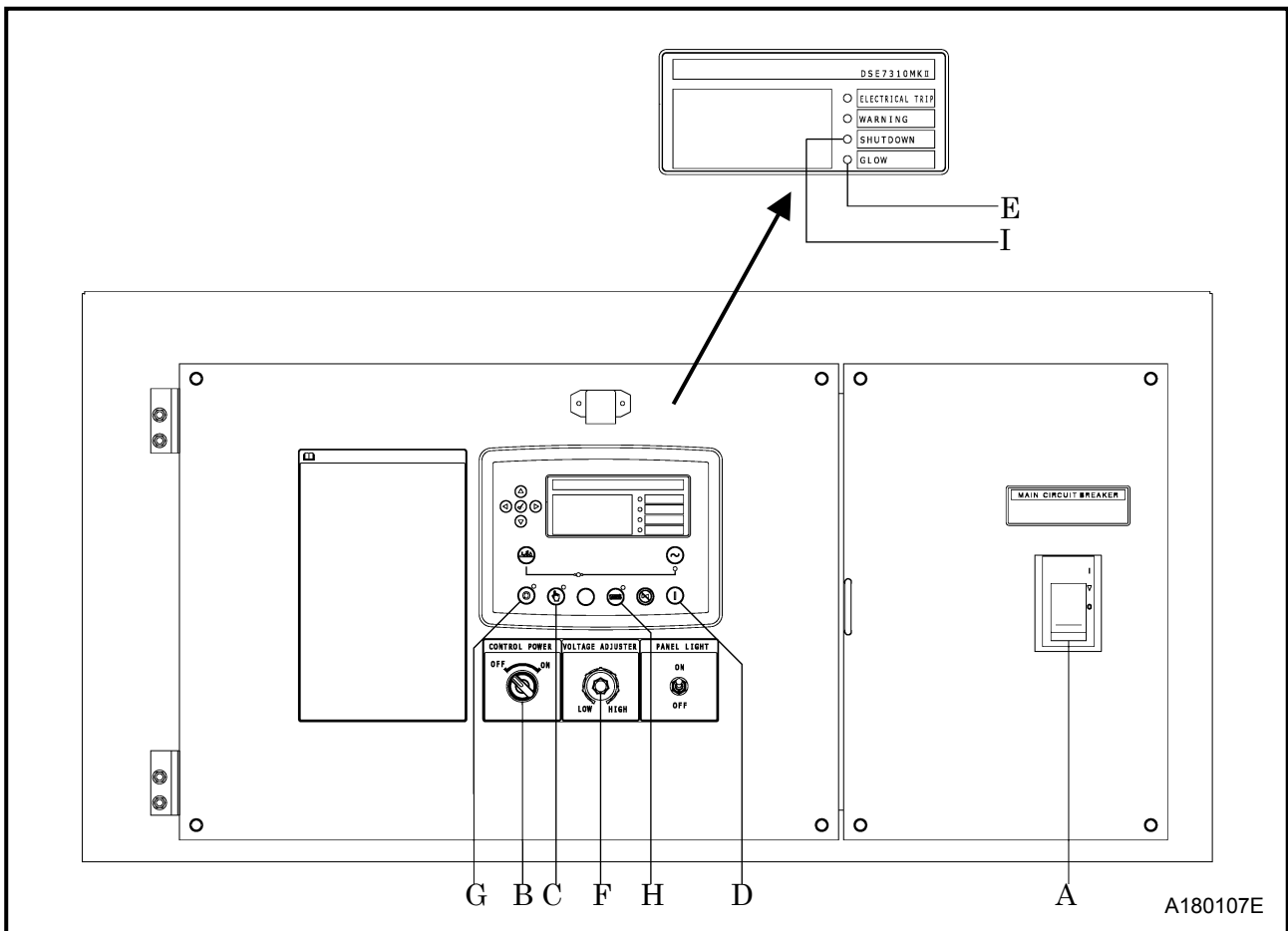

- Keep the output terminal cover shut and locked whenever the machine is running. Notice that the voltage of several hundred volts is applied to the output terminal and control board. When opening the output terminal cover is unavoidable, be careful not to touch the output terminal. It could cause an electric shock and serious injury.

3. Operation

Confirmation of voltage and frequency

<Procedures>

1. Check that the frequency of the generator is at 60Hz after warm up.

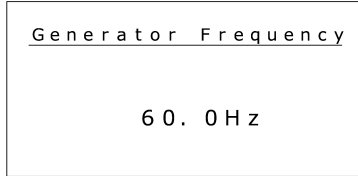

Monitor screen display

2. Adjust to rated voltage with a voltage adjuster [F].

Generator Voltage	
L 1-L 2	480V
L 2-L 3	480V
L 3-L 1	480V

Monitor screen display



Voltage regulator

Load Operation

<Procedures>

1. Set the circuit breaker [A] to [ON] and supply power to the load.
- During operation, check and confirm whether the generator functions properly.
- ※Before starting to supply power to the load, make sure that the voltage is in accordance with the load.

IMPORTANT

- After the engine starts up, warm up it under unload for approx. 5 minutes.
- Warming up after starting up is necessary for smooth operation of the engine. Do not operate the engine at full load immediately after it starts up. This will shorten the equipment life.
- During the warm-up operation, examine the different parts of the equipment for any looseness, leakage of water, oil, fuel, and other irregularities.
- Also, make sure that the alarm lamps are off.
- Be sure to operate the generator at the rated frequency, irrespective of the load capacity. If the machine is operated with a frequency lower than the rated frequency, it could cause the generator main machine or to be burned.

<Normal Shutdown Procedures>

1. Set the circuit-breaker [A] to [OFF] position.
2. After about 5 minutes cooling down operation, push the stop button [G] to stop the engine.
3. Set the power control switch [B] to [OFF] position.

※The engine controller will continue operating for approx. 3 minutes after engine is stopped. Do not remove the battery cables, etc., during this period.

3. Operation

Automatic Operation

1. Cable connection method of remote control switch

- The remote control terminal [J] is provided inside the output terminal. Perform cable connection as shown below for remote control operation of the machine. For this cable connection job, make sure to remove the battery cathode cable terminal.

<Procedure>

1. Perform manual start to adjust voltage, stop the engine.
2. Push the auto mode button [H].
3. Set the circuit breaker [J] to [ON] position.
4. Setting remote control terminals [A1] and [A2] to ON starts the engine.
(In cold conditions, pre-heating starts automatically. After GLOW lamp [E] is switched off, the engine starts.)
5. Setting remote control terminals [A1] and [A2] to OFF stops the engine.

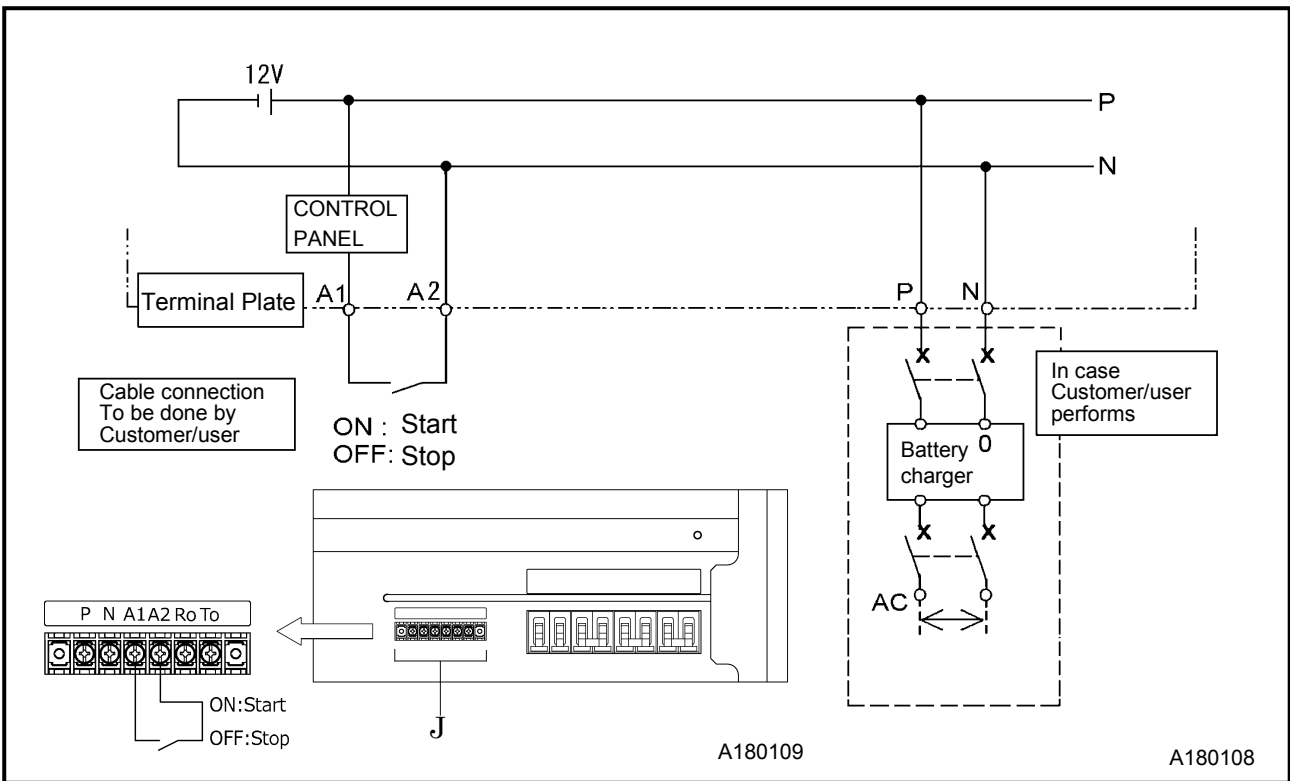

Inspection and maintenance prohibited during automatic operation



- Never put your hands close to the interior of the machine, because the generator can be started when start signal functions even while the machine is in stop position.
- Before starting inspection and maintenance job, make sure to hang the tag "Under inspection and maintenance."
- Remove the battery cathode cable terminal.



Install the battery charger Install the battery charger

- While the machine is in stand-by conditions during automatic operation, battery discharge occurs.
Make sure to charge battery, operating the battery charge

3. Operation

2. Function

- When the start signal activates in stand-by mode, it starts the unit. (This includes preheating.) When the stop signal activates, the unit will continue to operate for 10 seconds to cool down, then the unit stops and is placed again in stand-by mode.

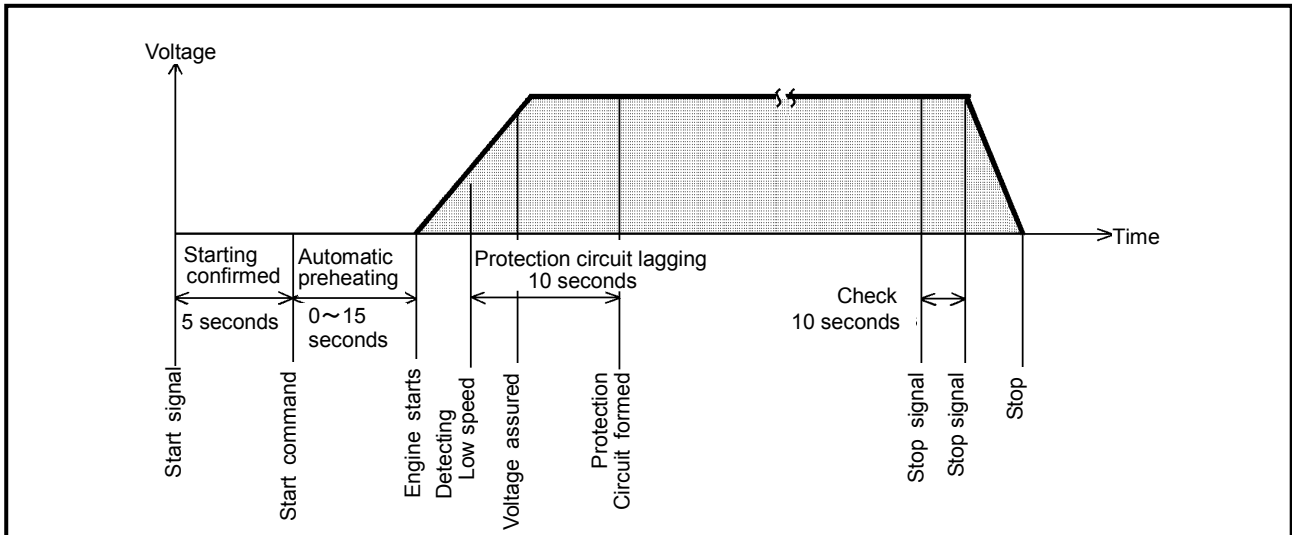

3. Starting Action

- If the engine will not start even after cranking operation for 10 seconds, stop it for 8 seconds and then try cranking operation again. If the engine will not start even after cranking operation is repeated three times, the SHUTDOWN lamp [I] will illuminate due to “Fail to Start”.
- If the engine will not start with the SHUTDOWN lamp [I], get rid of the cause of trouble why engine would not start.

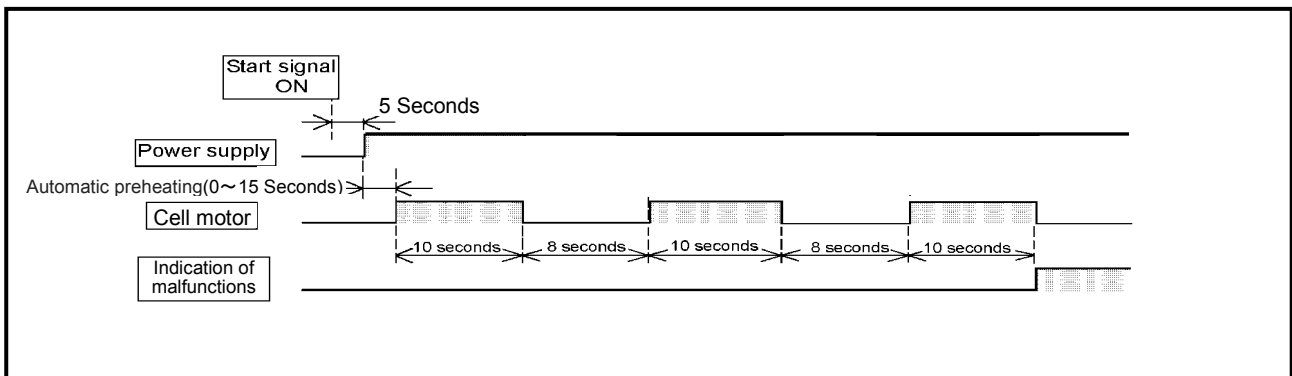

Perform periodical inspection and maintenance of the generator

IMPORTANT

- To check performance, run the unit 5 to 10 minutes once a week.

3. Operation

3.5.2 Meters and indicator lights during operation

During normal operation, each indication of instruments is shown in the table below. Refer to the table for daily checks.

Note: The values marked ※ vary with location of the voltage selector switch.

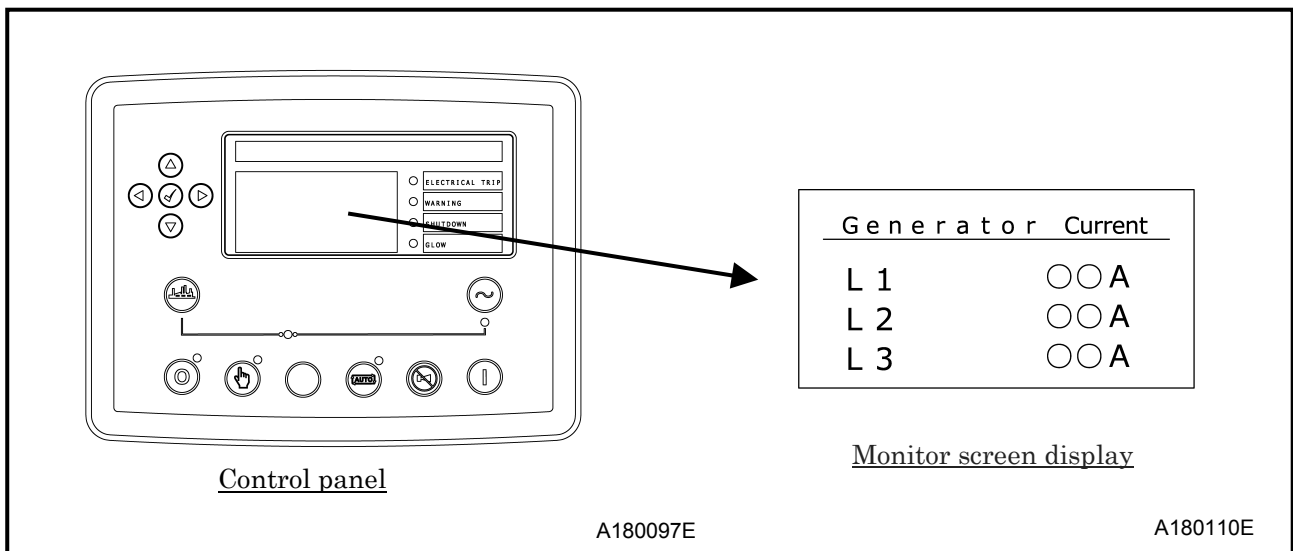

		Voltmeter (V)	Frequency meter (Hz)	Ammeter (A)	Control panel lamp			
					ELECTRIC TRIP	WARNING	SHUTDOWN	GLOW
Before Starting up (RUN)	CONTROL POWER SWITCH (ON)	0	0	0	● OFF	● OFF	● OFF	● OFF
		※ 240 480	60	Less than rated current	+● OFF			



- Be sure to frequently check meters and indicators for proper operation and to check for any water, oil, fuel leaks, etc.
- The above table gives standard values. They may vary slightly depending on operating conditions and other factors. In single-phase load operation, check the current of L1, L2, and L3 phase with the ammeter, by turning the ammeter change-over switch.
- Each current should be balanced if unbalanced. Change load connections so the current of L1, L2, and L3 is equally balanced. Make sure that the current of each phase does not exceed the rated one.

※Keep the operation log to record constant inspection of each component, so that trouble of the machine can be easily discovered and preventive measures can be taken.

3. Operation

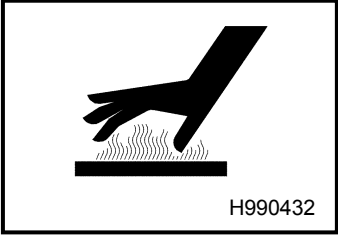
	 PK0028	<ul style="list-style-type: none">● Do not under any circumstance, open the portions below during operation.<ul style="list-style-type: none">● Coolant drain valve● Engine oil drain valve
	 H990432	<ul style="list-style-type: none">● Never work nearby hot portions of the machine while it is running.● Do not touch hot portions of the machine while inspecting the machine when running.● Parts such as the engine, exhaust manifold, exhaust pipe, muffler, and radiator and intercooler are especially hot. Never touch those parts, because it could cause scalding.● Coolant water and engine oil are also very hot and dangerous to touch. Avoid checking or refilling them while the machine is running.
		<ul style="list-style-type: none">● When the breaker functions often during operation, reduce the load.● When using 1-phase load, check the current of each phase and try to keep the load of each phase constantly average.● If you continue to operate the generator while ignoring or neglecting these cautions, it could cause overheating and result in fire. Furthermore, should operation continue at a lower level than the standard rated frequency, it could burn the generator and any motors of the attached load.

3.5.3 Panel light

- The instrument panel are provided with transmission type illuminators. Switch [ON] the panel light so that they may light on.
- When illumination is not necessary, turn the light [OFF]. If the machine is always operated with the lamp switched [ON], the lamp life can be reduced.

3.5.4 Operating procedures when engine fails to start up on first attempt

If normal procedure does not allow the engine to run, check the following:

- No fuel
- Clogging of the fuel filter
- Discharge of battery (Low cranking speed)

3. Operation

3.5.5 Fuel line air bleeding device

If the machine runs out of fuel, bleed the air according to the following procedures.

<Procedure>

1. Refill the fuel.
2. Set the control power switch [A] to [ON] position.
3. Push the manual mode button [B].
4. The electric pump will start to automatically bleed air from the fuel line.
5. Air bleeding will be completed within 60 seconds.

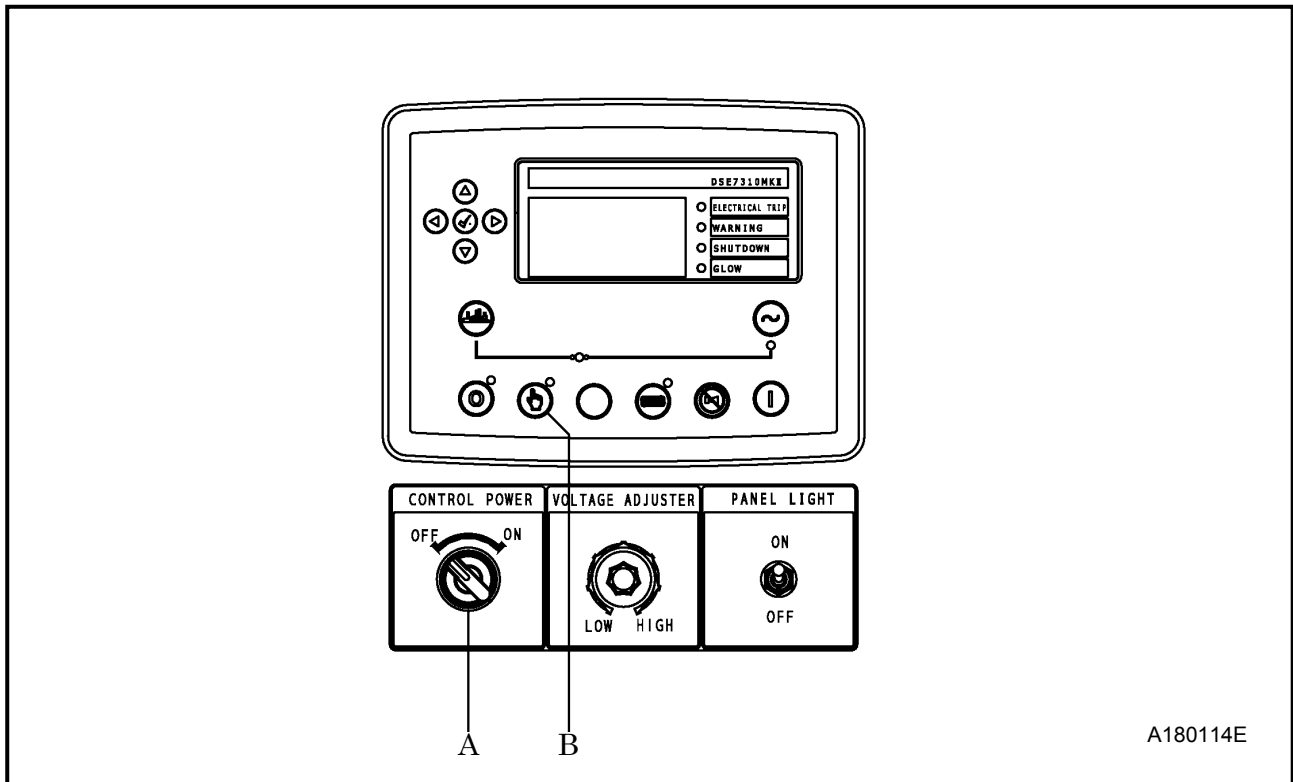

3. Operation

3.6 Emergency Stop

3.6.1 Emergency stopping procedures

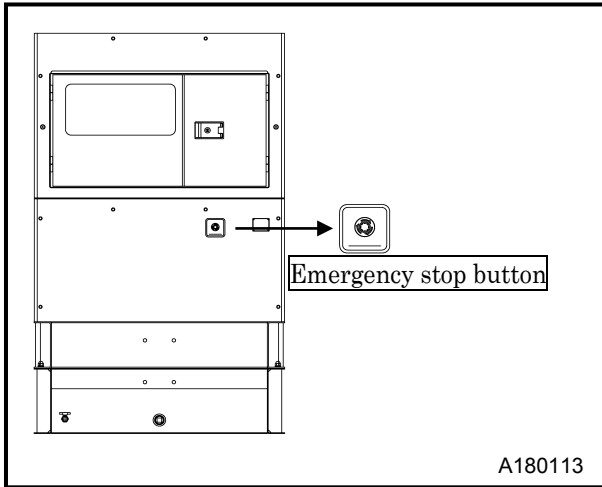

- If it is necessary to stop the generator for emergency, press the Emergency Stop button which set up under part of the control panel. When shutting down with the emergency stop button, the machine will be stop immediately.

3.6.2 Cancellation of emergency stop button

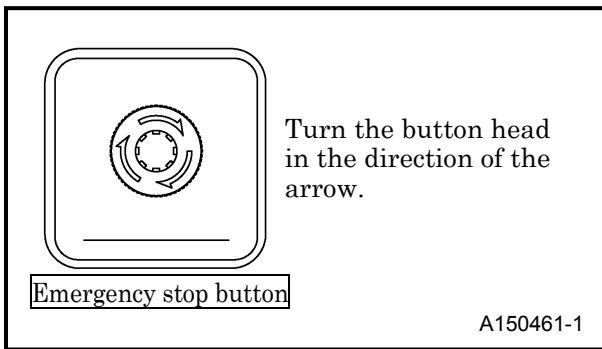

- After emergency stopping, be sure to carry out an investigation of the problem which caused you to use the emergency stop and take appropriate countermeasures. Release emergency stop button after making sure the safety was confirmed. To reset the button, turn the button head in the direction of the arrow.

※If it is not reset, the machine cannot restart operation.

3.7 SCR Cleaning

3.7.1 Natural Cleaning

- Periodically, the exhaust filter will experience higher heat levels through the engine operating at higher loads. During these times, the higher exhaust heat will clean the SCR system to allow it to maintain normal function. No operator action is required.
- The unit can be operated normally during this type of cleaning.

3.7.2 Automatic Cleaning

<p>WARNING</p>	<ul style="list-style-type: none">● During auto or manual exhaust filter cleaning operations, the engine will run at elevated idle and a high temperature. Exhaust gases and exhaust filter components reach temperatures hot enough to burn people, or to ignite or melt common materials.
----------------	---



- When enough soot has built up in the exhaust filter, exhaust temperatures are increased to perform the exhaust filter cleaning automatically. No operator action required. The unit can be operated normally during this type of cleaning. Cleaning usually takes about 15 minutes to complete.
- During the process, High Exhaust System Temperature (HEST) symbol [] is displayed. This is normal during this type of cleaning.

3. Operation

3.7.3 Manual Cleaning

- If manual cleaning is required, the SCR symbol [] will be displayed on the monitor. Operator is required to perform the procedure below to set “SCR Manual Cleaning” to “Active” from “Inactive”.





<Procedure>

1. Press and hold the tick  button to access the *Running Editor*.
2. Press the right arrow  button until “Editor – Engine” is displayed.

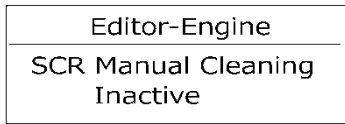

3. Press the down arrow  button until “SCR Manual Cleaning” is shown.









4. Press the tick  button to edit, press the up arrow  to change to “Active,” press the tick to  confirm.
5. It will take approximately 40 to 50 minutes to complete the exhaust filter cleaning.
6. During cleaning, SCR symbol [] will blink and HEST symbol [] will be displayed solid.
7. When the cleaning process has completed, the manual cleaning setting will be switched back to “Inactive” automatically and indicator will be turned off.

	<ul style="list-style-type: none"> ● The engine de-rating occurs during manual cleaning. Set the breaker to OFF to stop power supply to the load because the engine output will be reduced to 50%. ● Do not stop the engine until the manual cleaning is completed.
---	---

3.7.4 Service Cleaning

- Failure to perform cleaning, manual and automatic, will result in engine de-rate and then in shutdown. Contact your local service center to restore engine function.

3.7.5 SCR Cleaning monitor display



State Description	SCR Cleaning	NATURAL	AUTO	MANUAL	SERVICE
	ENG.OUTPUT	100%	100%	50%De-rate	-
Indicator	SCR symbol	-	-		
	ECU Alarm	-	-	 	 
	Warning lamp	-	-	●:ON	●:ON
	Shutdown lamp	-	-	-	●:ON
	HEST symbol	-	-		-

3. Operation

3.7.6 Automatic Cleaning Inhibit

- If the exhaust temperature is too high and dangerous, disable the automatic SCR cleaning.



<Procedure>

1. Press and hold the tick  button to access the *Running Editor*.
2. Press the right arrow  button until “*Editor – Engine*” is displayed.

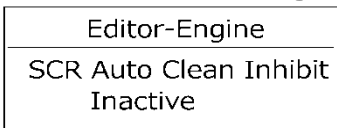

3. Press the down arrow  button until “*SCR Auto Cleaning Inhibit*” is shown.















4. Press the tick  button to edit (Inactive begins to flash), press the up arrow  to change to “Active,” press the tick to  confirm. (Active ceases to flash)

CAUTION 	<ul style="list-style-type: none"> ● Disabling the auto SCR cleaning is not recommended. The SCR Automatic Exhaust Filter Cleaning Inhibitor should always be set “Inactive” unless it is necessary.
---	---

3.8 SCR Inducement

- The warnings below will be indicated before the situation become critical when sensing problems such as no DEF supply, use of poor quality DEF, DEF injection issues, or disconnection of sensors.
- If no action is performed, the engine will begin derating 2 hours later and will shutdown 4 hours later.
- If the engine stops in this condition, John Deere service software is required to restore operation.

[Monitor display during SCR inducement]

State Description	-	Detect	0.5Hr From detect	1.0Hr From detect	1.5Hr From detect	2.0Hr From detect	4.0Hr From detect	
	Warning Level	Normal	Initial Notification	1 st Warning	2 nd Warning	3 rd Warning	Final inducement Warning	Final inducement Reached
ENG.OUTPUT	100%	100%	100%	100%	100%	100%	50% De-rate	-
Indicator	SCR system malfunction	-						
	ECU Alarm	-						
	Warning lamp	-	●:ON	●:ON	●:ON	●:ON	●:ON	●:ON
	Shutdown lamp	-	-	-	-	-	-	●:ON

CAUTION 	<ul style="list-style-type: none"> ● If the SCR system malfunction symbol is displayed during normal operation, stop the engine immediately and contact the nearest service center.
---	--

4. Failure and Troubleshooting

4.1 Protection device

For prevention of troubles during operation, this machine is provided with various protection devices.

4.1.1 List of protective devices, warning lamps, and monitor alarms

This machine is equipped with protective devices as shown in the table below, and these perform the actions marked with “O” according to the types of troubles to be experienced. Shown below are the typical items. When the warning lamp is activated or any other monitor alarm is displayed due to other engine trouble, contact your local service center.

Item	Control panel					Functions
	Lamp				Screen	
	ELECTRICAL TRIP	WARNING	SHUTDOWN	GLOW	Alarms,DTCs	
Low engine oil pressure	-	○	-	-	○	Warning lower than:180kPa
	○	-	○	-	○	Shutdown:lower than160kPa
High coolant temp.	-	○	-	-	○	Warning:above114°C
	○	-	○	-	○	Shutdown:above116°C
Low coolant level	-	○	-	-	○	Warning: coolant level is low
	○	-	○	-	○	Shutdown:coolant level is extremely low
Over speed	○	-	○	-	○	Shutdown:above 2070min ⁻¹
Clogging air filter	-	○	-	-	○	When it is clogged or Necessary to clean
Oil fence	-	○	-	-	○	When more condensate (fuel,engine oil and coolant) Than 1/3 of capacity in the Oil fence is accumulated
☆Low fuel level	-	○	-	-	○	Warning:less than 5% of capacity
Over current short circuit	○	-	-	-	○	When it occurs
High voltage	○	-	○	-	○	Shutdown:above 108%
Glow	-	-	-	○	-	In cold temperature
Other engine trouble	※	※	※	-	※	※Please refer to engine DTC code

☆Not perform when the external fuel tank is used.

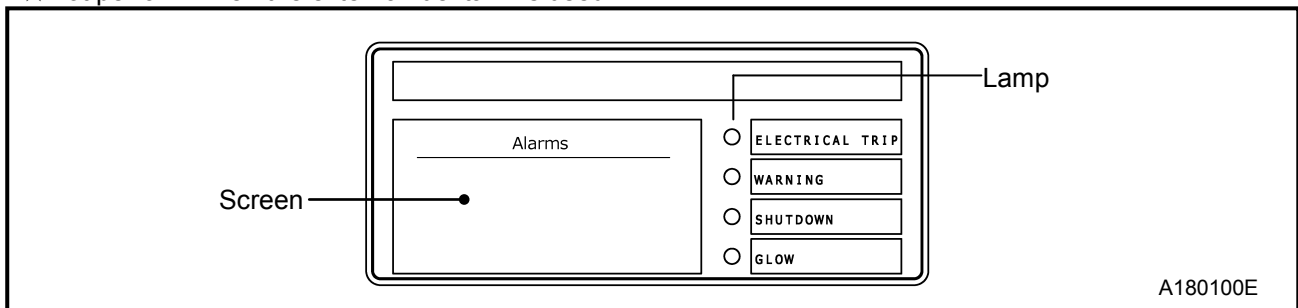

A180100E



- Disable the automatic exhaust filter cleaning only when necessary.
- The engine will shut down if the unit is run with the auto cleaning inhibits.

4. Failure and Troubleshooting

4.1.2 Circuit Breaker

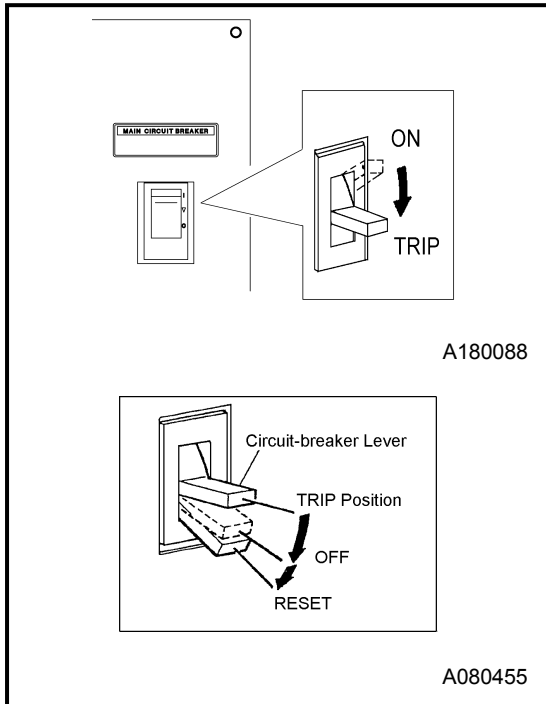

- In case of overload or short-circuited wire connection, the circuit-breaker trips.
- When tripped, stop the machine immediately and reset the circuit breaker after resolving the causes of the trouble.

<How to reset>

- In order to reset the lever of circuit breaker, press the lever downward firmly until the lever sounds “click.”

4.1.3 Circuit protector (CP) for AVR protection

AVR is equipped with a circuit-protector (CP) for protection against over current. It will activate under the following conditions.

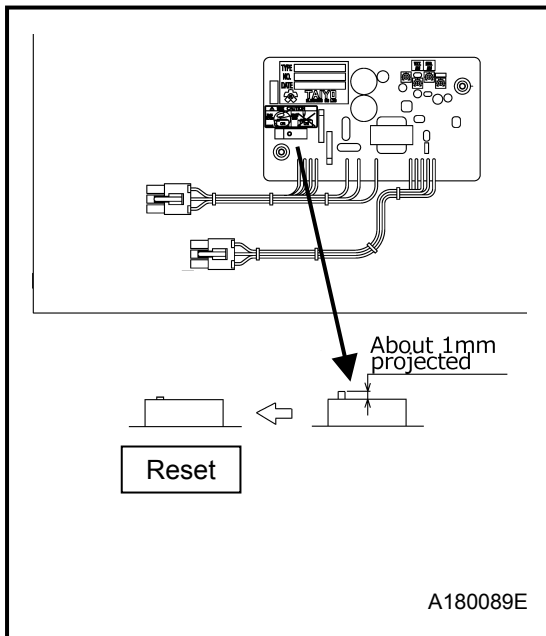

- The machine is overloaded while engine speed is still low.
- The output voltage of machine is increased higher than the specified voltage.

<Symptom>

- When the CP operates, following symptoms will occur.
(1)The voltage will not reach rated voltage.
(2)The voltage is usable but voltage fluctuation is wide and voltage restoration is slow when loaded.

<How to reset>

- Press it by pressing CP(AVR) button provided at the side of the breaker plate in the control panel.

Note:Do not hold the button with such sharply pointed things as a screwdriver, ball point pens etc.

4. Failure and Troubleshooting

4.2 Troubleshooting

Should any trouble occur during operation, do not leave it. Investigate the cause and take appropriate measures. Read the manual carefully and fully understand what to do in case of trouble.

- The better you understand the construction and function of the machine, the faster you can find a problem and solution.
- This chapter describes the state, cause and countermeasures of important troubles in detail:

Symptom	Cause	Counter measures
Starter does not rotate. Low starter revolution speed even when starting.	(1)Battery malfunction (2)Charging malfunction (3)Alternator malfunction (4) Starter malfunction	Check Battery→Charge /Change Change Change
Starter rotates normally but engine does not start up.	(1)No diesel fuel oil (2)Air mixing in fuel piping (3)Fuel filter clogging (4)Nozzle clogging (5)Malfunction of controller	Replenish fuel Bleed air Disassemble and clean Disassemble and clean Check fuse Check connector Check controller
Low engine oil pressure	(1)Engine oil shortage (2)Engine oil filter clogging (3)Loosened or disconnected wiring, or connector (4)Oil pressure switch malfunction	Replenish fuel Change Check/tightening Change
High coolant temperature	(1)Shortage of coolant (2)Slip of belt (3)Radiator clogging (4)Faulty thermostat (5)Looseness, disconnection of wiring or connectors (6)Faulty coolant temperature switch	Replenish Adjust tension Clean Change Check/tightening Change
Air filter clogging monitor lamp glows.	(1)Air filter clogging	Clean
Oil fence lamp	(1)The condensate (fuel, engine oil and coolant) is accumulated in the oil fence. (2)The liquid surface level detecting switch does not function good.	Drain the condensate Check/change
Control panel lamp illuminate	(1)Engine trouble	※1

4. Failure and Troubleshooting

Symptom	Cause	Counter measures
Circuit breaker trips.	(1)Overloaded (2)Short-circuit occurred at the load side.	Reduce the load Get rid of cause of short-circuiting.
Even when operated at a rated speed, no voltage or too low voltage generated.	(1)Poor tightening of terminals (2)Broken or short-circuited circuit to exciter field winding (3)Faulty exciter (4)Function circuit protector (CP) for AVR protection (5)Faulty AVR (6)Broken or short-circuited winding of generator main machine (7)Faulty silicon rectifier (mounted on generator main machine rotor) (8)Faulty control panel	Check/tightening Repair Repair Reset Change Repair Change Change
Too high voltage generated when set at the rated frequency (50Hz/60Hz), Voltage will not drop even when the voltage regulator controlling knob is turned.	(1)Loosened or disconnected wiring, or connector to AVR (2)Broken wire or poor contact of AVR variable resistor (3)Faulty AVR	Check/tightening Repair or change Change
Unstable voltage generation	(1)Poor tightening of each terminal (2)Function circuit protector (CP) for AVR protection (2)Faulty AVR	Check/tightening Reset Change

- ※1 After having found the cause with a service tool, it is necessary to take measures. Therefore, please contact your nearest distributor.
- Please contact your nearest dealer if you find it difficult to repair by yourselves.
- For engine troubles other than those on page 4-3, please refer to the engine operation manual.

5. Periodic Inspection/Maintenance

5.1 Important Items at Periodic Inspection and Maintenance or after Maintenance

The following table shows the inspection and maintenance intervals under normal operation conditions. When used or operated under hard environmental conditions, it is impossible to warrant the machine even if the above conditions are performed according to the intervals listed in the above table.

- Be sure to use appropriate tools for inspection and maintenance work. Inappropriate tools could cause unexpected injury.
- Please wear protective gear, such as a helmet, protection glasses, earplugs, safety shoes, gloves, and a dust mask, according to the contents of work for safety.
- Do not touch hot portions of the machine while inspecting the machine when running. Parts such as the engine, exhaust manifold, exhaust pipe, exhaust muffler, radiator, inter cooler, generator, and pipe are especially hot, so never touch those parts, because it could cause scalding.

Hang a "Now Checking and under Maintenance" tag

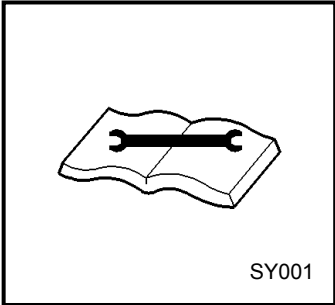
		<ul style="list-style-type: none"> ● Before starting inspection, set the machine's circuit breaker to OFF, and then attach the "Under Inspection" label to an easy-to-see location. ● Remove the negative (-) side cable from the battery. If the above procedure is neglected, and another person starts operating the machine during check or maintenance, it could cause serious injury.
--	--	---

Instructions and unspecified work ban

	<ul style="list-style-type: none"> ● Be sure to use recommended fuel, DEF, oil, grease, or antifreeze. ● Do not disassemble or adjust engine, compressor or part(s) for which inspection or maintenance is not referred to in this manual. ● Use genuine parts for replacement. ● Any breakdown, caused by using unapproved parts or by wrong handling, will be out of the scope of "WARRANTY." ● Do not pour water or steam on electrical components. ● Place a container or a pan underneath the oil port to receiver waste liquid so that such liquid cannot be spilt out on the floor or inside the machine. ● Be sure that no waste liquid is disposed of on the ground. Such waste on the ground, river or lake will cause serious environmental contamination. Be sure to follow the local regulations. If harmful material such as oil, antifreeze solution or filters are disposed of incorrectly, the responsible person should be punished by the authority. ● Observe local regulations when disposing of such toxic materials as oil, fuel, coolant (Antifreeze), filters, and battery etc.
---	--

5. Periodic Inspection/Maintenance

5.2 Periodic Inspection List

Such items marked ○ shall be carried out by customers.

For the following items or clauses marked ●, contact us directly or our distributors because they require expert technical knowledge on them.

The following table shows the intervals of inspection and maintenance under normal operation conditions. Inspection and maintenance should be done at either of the hour or the period mentioned in the remarks column, whichever comes earlier.

(This table is a guide only, it is not a guaranteed time. Please change maintenance interval according to usage load environmental condition.)

(Unit : Hour)

Maintenance		Daily	100	250	500	1,000	Page	Remarks
Generator	Clean instruments in control panel	○					3-12	Cleaning should be done when needed.
	Check thermo-label on the stater	○					3-12	
	Check control panel	○					3-18	
	Check GFCI receptacles			○			5-8	Every 1 months
	Check insulation resistance			○			5-9	Every 2 months
	Check thermo-label on the rotor bearing			○			5-10	Every 2 months
Engine related	Check engine oil level.	○					3-9	
	Check coolant level.	○					3-10	
	Check fuel	○					3-10	
	Check fuel pre-filter drain	○					3-11	
	Check DEF Level	○					3-11	
	Check belt tension.	○					3-12	In the case of NG, it exchanges.
	Change engine oil.		○ (First time)		○		5-4	
	Change engine oil filter		○ (First time)		○		5-5	
	Check battery			○			5-5	
	Check and clean air filter element			○			5-7	Perform cleaning when the monitor lamp glows.
	Check exhaust system			○			5-8	
	Drain water from fuel tank			○			5-10	
	Check specific gravity of battery electrolyte				○		5-5	
	Change fuel filter element				○		5-10	
	Change fuel pre-filter element				○		5-11	
	Clean outside of radiator and intercooler				○		5-11	Dirt condition cleans.
	Drain condensate out of intercooler.				○		5-11	
	Check for crack and leak on the exhaust flexible pipe				○		5-12	Every 4 months
	Change air filter element					○	5-13	
	Change coolant. (LLC)						5-16	Replaced every 2 years
Clean fuel tank					●			
Others	Check interior	○						
	Check oil fence drain	○						
	Check terminals and connections				○		5-12	Every 4 months
	Check vibration isolators					○	5-15	Every 1 year
	Check each rubber hose					○	5-15	Every 1 year
Clean oil fence					●	5-14	Every 1 year	

The above intervals of inspection and maintenance are respectively based on the operation time of 125 hours of used per month and of 1,500 hours of use per year.

5. Periodic Inspection/Maintenance

Unit: Hour)

Maintenance		1,500	4,500	Page	Remarks
Engine body	Change of OCV filter	○		5-13	
	Change DEF Dosing Unit Filter		○	5-17	
	Clean DEF tank				As needed when dirty

5.3 Periodic Replacement of Parts

Part number changes upon modification.

For replacement of parts, make sure whether the part number is correct or applicable.

Part Name	Part Number	Quantity
Air filter element	32143 12500	1
Engine oil filter	JOHN DEERE RE539279	1
Element for pre-fuel filter	JOHN DEERE RE551507	1
Element for fuel filter	JOHN DEERE RE560681	1
Belt	JOHN DEERE R529382	1
OCV filter	JOHN DEERE DZ105796	1
DEF Dosing unit filter	JOHN DEERE RE554498	1

5. Periodic Inspection/Maintenance

5.4 Maintenance

5.4.1 Change Engine Oil

At 100 hours for the first change and every 500 hours thereafter

When checking, replenishing, and draining the engine oil, be sure to wait 10 to 20 minutes after engine stops to allow it to cool down.

<Procedure>

1. Remove the drain plug [A] attached outside the plane, open a drain valve [B] inside the plane, and discharge engine oil drain.
2. After draining, close drain valve [B] and install drain plug [A]. Then, remove cap [C] of the engine oil port (also used for the oil level gauge) and supply engine oil.

[Oil supply: about 33L]

3. After finishing the oil supply, tighten the cap of oil filter port firmly.
4. Please be sure to check the engine oil level with an oil level gauge before operating this machine.
5. When the correct engine oil level is obtained, tighten the oil port cap (also used for the oil level gauge) securely.

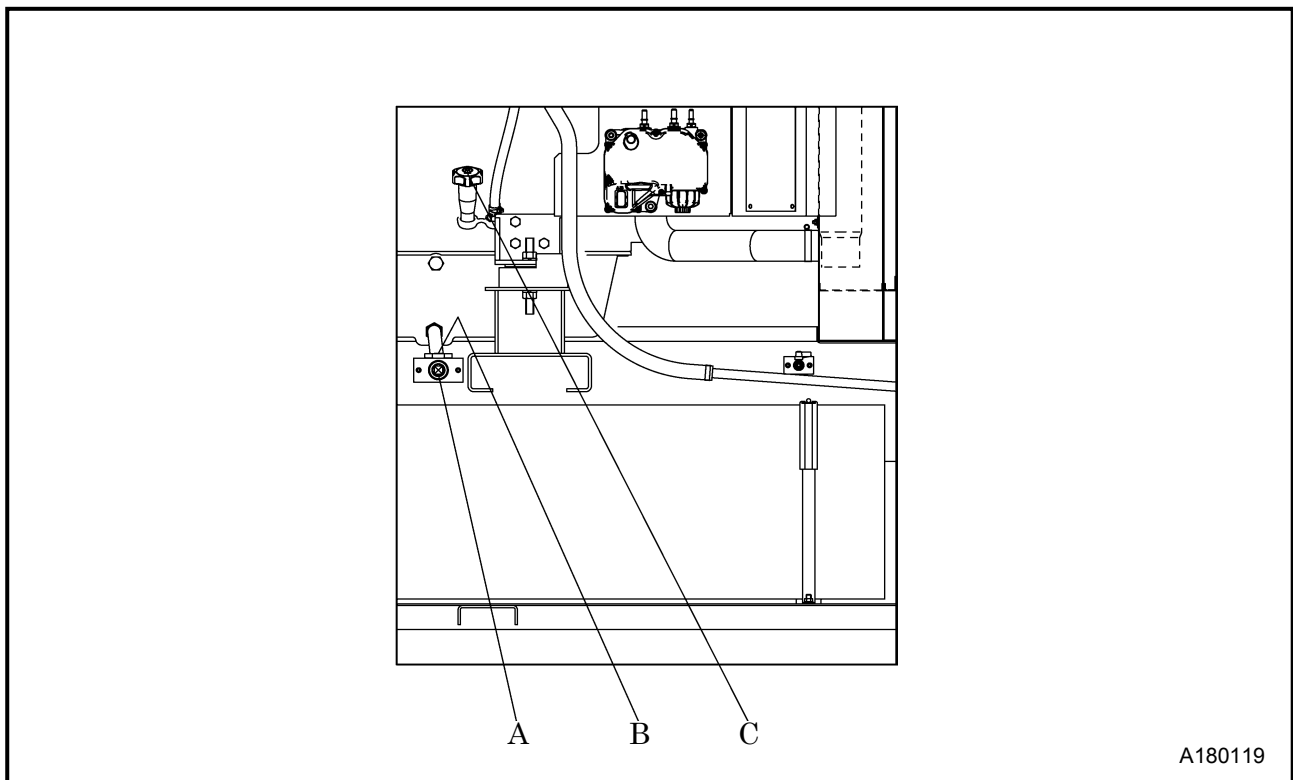

A180119

Caution in filling or draining engine oil

CAUTION

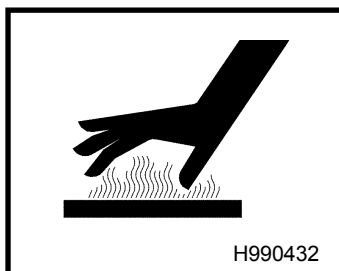

- Engine oil is very hot and highly pressurized during or just after the operation. Hot oil could blow out and can cause injury.
- Never supply more engine oil than the proper level. Too much oil could cause white smoke out of the exhaust, and it can cause damage and accident to engine.

5. Periodic Inspection/Maintenance

5.4.2 Change Engine Oil Filter

At 100 hours for the first change and every 500 hours thereafter

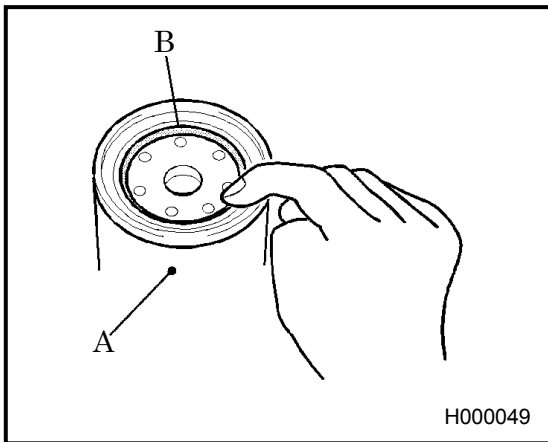

<Procedure>

1. Take out the oil filter [A] by using a filter wrench.
2. After coating fuel on the new oil filter packing [B], screw it in. After the packing touches the sealing face, tighten another 2/3 turn with a filter wrench.
3. After installing an oil filter, check for fuel leakage during operation. **(For part number, See Section 5.3)**

5.4.3 Check battery electrolyte and specific gravity of battery electrolyte

Battery electrolyte : every 250 hours

Specific gravity of battery electrolyte : every 500 hours

If there to be a problem in starting an engine due to a flat battery, carry out the checks by following the procedures below:

● Ordinary type battery:

Measure specific gravity of battery electrolyte, and if it shows below 1.24, recharge the battery immediately. **(See Section 5.4.4)**

● Enclosed type battery:

Check the indicator on top surface of the battery.

If the indicator shows that charge is needed, recharge the battery immediately.

If specific gravity of battery electrolyte does not rise despite replenishing distilled water or charging battery, replace battery with a new one quickly.

5. Periodic Inspection/Maintenance

5.4.4 Maintenance of Battery



Battery may generate hydrogen gas and may explode.

Therefore, recharging should be done at a well-ventilated place.

- Do not check the battery by short-circuiting the positive and negative terminals with a metallic piece.
- Never operate the machine nor charge the batteries with low battery liquid. Continuing operation at this lower level will cause deterioration of some parts, reduction of battery life, and also it may cause explosions.

Add distilled water so that the liquid level is between the “UPPER LEVEL” and “LOWER LEVEL” if the level is too low.

- Wear protective gloves and safety glasses when handling a battery.
 - If battery electrolytes contact your clothes or skin, wash it away with a large amount of water immediately.
 - If the battery electrolytes get into your eyes, flush them immediately with plenty of water and see a doctor at once. Severe damage to eyes and vision may result.

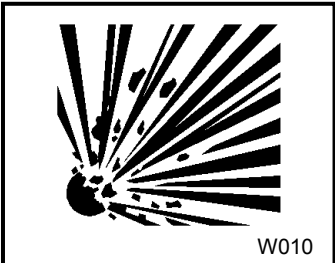
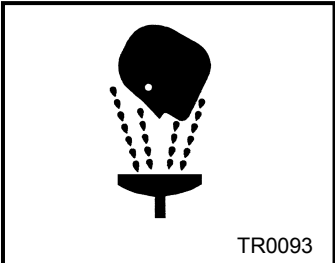
Handling battery	
 WARNING	<div style="display: flex; flex-direction: column; align-items: center;"><div style="text-align: center;"> D004</div><div style="text-align: center;"> W010</div><div style="text-align: center;"> TR0093</div></div> <ul style="list-style-type: none">● Keep flames away from battery.● Do not spark near the battery nor light a match, nor bring lit cigarette and match close to the battery.● Do not charge a frozen battery as it may explode. If the battery is frozen, warm it up until the battery temperature becomes 16°C to 30°C.● Battery electrolyte is diluted sulfuric acid. In case of mishandling, it could cause skin burning.● Dispose of battery, observing local regulations.

[Charge battery]

- Use the battery charger after you confirm whether it is in good operating condition and ready for use.
- Disconnect the cable between battery and the machine, and charge the battery with a 12V battery charger. Do not charge two batteries at the same time.
- Be sure not to connect (+) and (-) terminals backwards.

5. Periodic Inspection/Maintenance

[How to use booster cable]

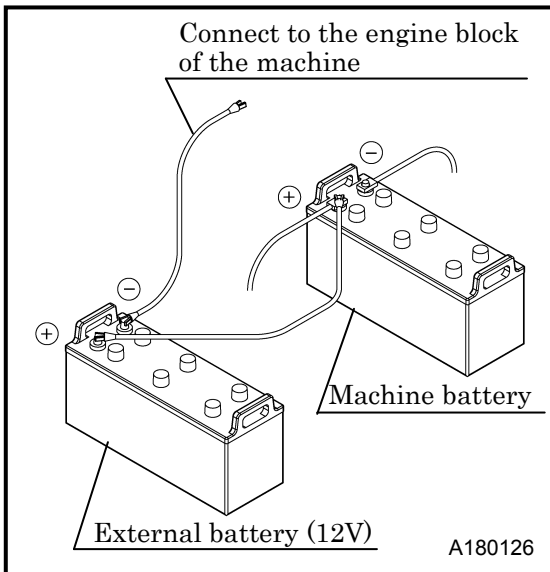

<Procedure for using a booster cable>

1. Stop the engine.
2. Connect one end of the (+) booster cable to the (+) terminal of the machine battery.
3. Connect the other end of the (+) booster cable to the (+) terminal of the external battery.
4. Connect one end of the (-) booster cable to the (-) terminal of the external battery.
5. Connect the other end of the (-) booster cable to the engine block of the machine.
6. Start up the engine.
7. Disconnect the booster cable by following the procedure back in the reverse order.

CAUTION



- When a booster cable has to be used or when cables are connected again after a battery is replaced, be careful not to connect (+) and (-) terminals backwards. A backwards connection will cause sparking and damage to each component.

5.4.5 Check and Clean Air Filter Element

Every 250 hours

When the air filter monitor lamp glows, clean the air filter.

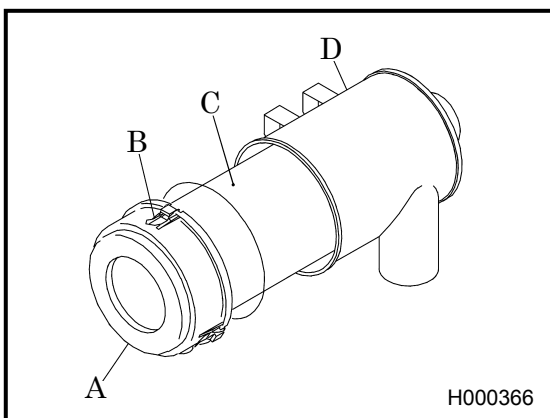

<Procedure>

1. After removing the cap [A] by loosening its cap fixing latch [B], clean its interior properly.
 2. Remove the element [C], and clean it.
 3. When installing the cap after finishing the cleaning job, push the element into the case [D] firmly by hand, and then make sure that the cap fixing latches attach securely to the case. Lastly, tighten the latches.
- If the element is found heavily dusty, replace it with a new one. **(For part number, See Section 5.3)**

IMPORTANT

- When an element that is clogged or has holes or cracks is used, dust or foreign material will get in the engine. This causes accelerated wear in moving parts within the engine. Be sure to perform daily checks and appropriate cleaning so that the life of the engine will not be shortened.

5. Periodic Inspection/Maintenance

5.4.6 Check Exhaust System

Every 250 hours

When a diesel engine driven generator is continuously operated with less than 30% load or no load for a long time, carbon will be stuck inside the exhaust pipes, exhaust muffler, and engine body. Unburned fuel may also come out from connected portions of exhaust pipe and outlet port of the exhaust muffler. If it is continuously operated under the conditions, the fuel which comes out could ignite and cause a fire.

Further, wet-stacking and carbon accumulation could cause power drop in the engine as well as overheating, resulting a serious damage to the engine. If this occurs, eliminate the carbon accumulation by burning it under full load operation (to increase exhaust heat) until the exhaust gas becomes almost clear.

(For load current, refer to the following table as a standard value.)

Frequency	Hz	60	
Rated voltage	V	240	480
Load current	A	288	144

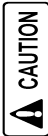

- In case of load operation, increase load factor, checking the conditions of exhaust. Carefully perform load operation, watching the surroundings because it could sometimes cause sparks.

5.4.7 Check GFCI Receptacles

Every 1 month or every 250 hours

Regularly check the GFCI operation for safety.

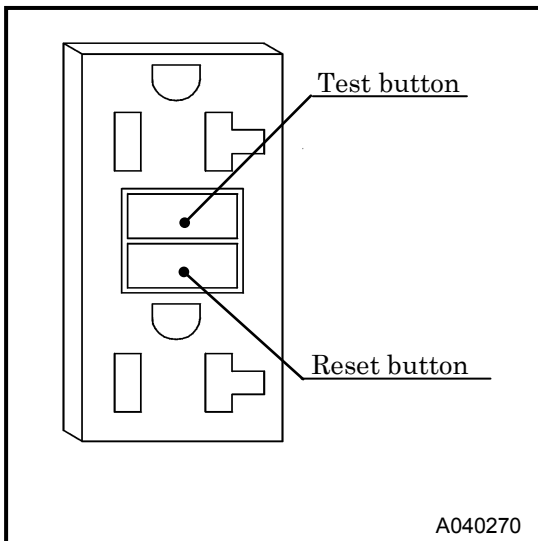

<Procedure>

1. Unplug all appliances from the generator.
2. Start the engine.
3. Turn [ON] the breaker on the instrument panel of this machine.
4. Press the TEST BUTTON
 - The RESET BUTTON should extend with a click.
 - If the RESET BUTTON does not extend, contact your nearest dealer.
5. Press the RESET BUTTON
6. When the RESET BUTTON extends during operation.
 - Unplug all appliances from the GFCI protected receptacle.
 - Press the RESET BUTTON:

IF THE GFCI CANNOT BE RESET: The GFCI is faulty. Contact your nearest dealer.

IF THE GFCI RESETS PROPERLY: Check the appliance or the power cord.



- If the generator is stored outdoors, unprotected from the weather, test the GFCI receptacle before each use.
- In case the GFCI has tripped due to the hazard of ground fault currents, investigate the cause and correct it.

5. Periodic Inspection/Maintenance

5.4.8 Check Insulation Resistance

Every 2 months or every 250 hours

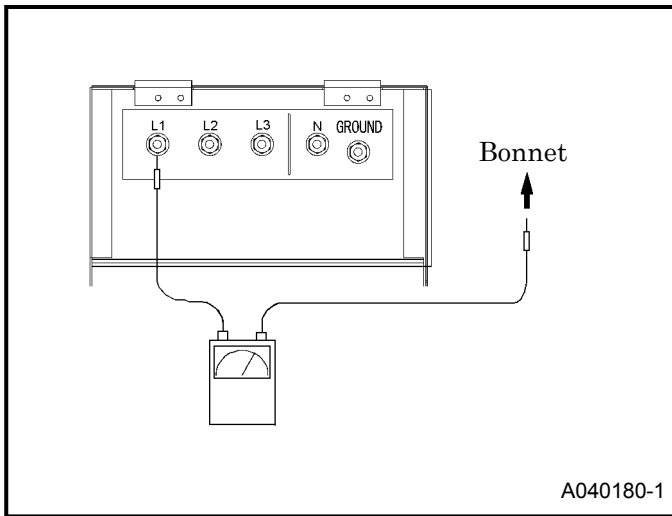

<Procedure>

1. Remove the load side cable from the output terminal board.
2. Loose and remove the bolt (M8) securing the ground cable between [N] and [GROUND] on the output terminal board.
3. Remove the AVR connector [A] inside the generator control panel.
4. Remove connector [B] at the rear side of the control panel.
5. Switch ON the three-phase breaker [C], measure each insulation resistance between the terminals L1, L2, L3 terminal and bonnet.
6. If insulation resistance value measured is found more than $1M\Omega$, it is good.
7. After checking the insulation resistance, reinstall the ground cable between [N] and [GROUND], AVR connector [A], and connector [B] at the rear side of the control panel.

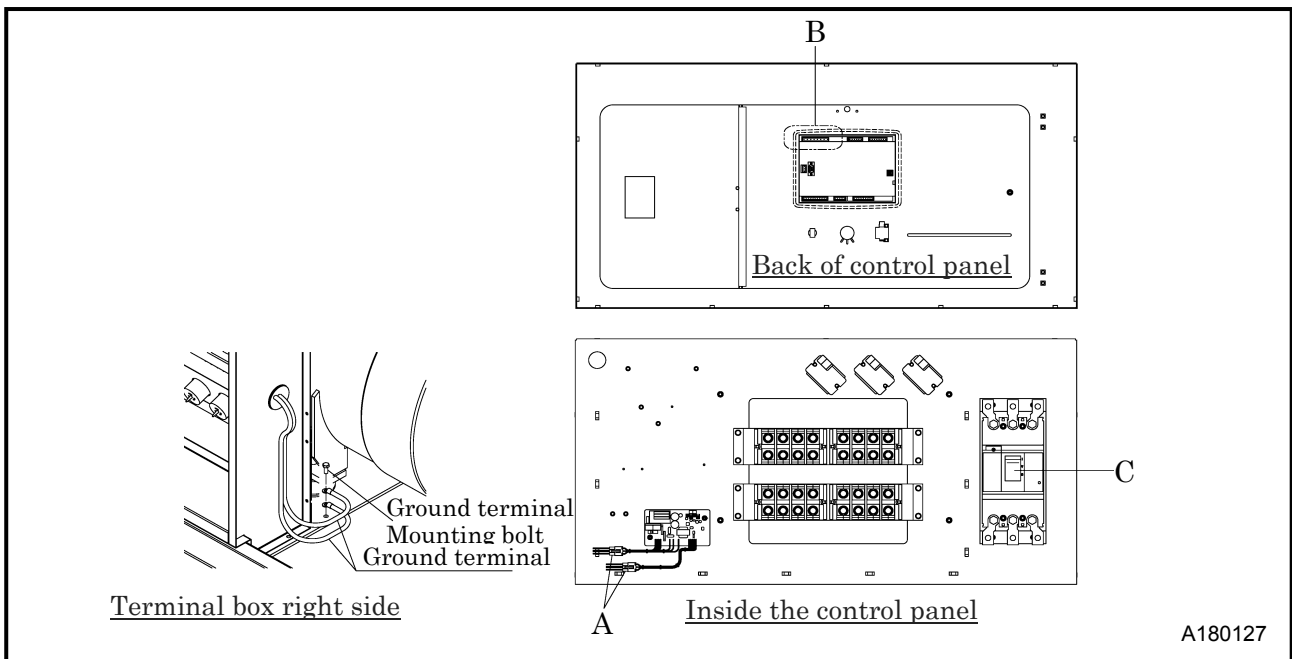

IMPORTANT

- Insulation resistance should be regularly checked or measured with a 500V insulation resistance meter. If it is reduced to lower than $1M\Omega$, it could cause an electrical leakage or a fire.
- For recovery or improvement of insulation resistance, wipe and clean dust and dirt around output terminals, circuit breaker, generator body outlet port and receptacle and dry them. If the insulation resistance does not recover after cleaning, contact your distributor.

⚠ DANGER

- After making sure that the insulation resistance of the generator is higher than $1M\Omega$, be sure to re-connect the cable between the terminal [N] and terminal [Ground] just as it was originally connected. If it is left disconnected, the grounding becomes imperfect so that it could cause electric shock.

5. Periodic Inspection/Maintenance

5.4.9 Check Thermo Label on the Rotor Bearing

Every 2 months or every 250 hours

Thermo-label on the rotor bearing irreversibly changes its color from white to blue by reaching or exceeding 80°C. Make sure to check the bearing for abnormal noise and vibration if it has changed color.

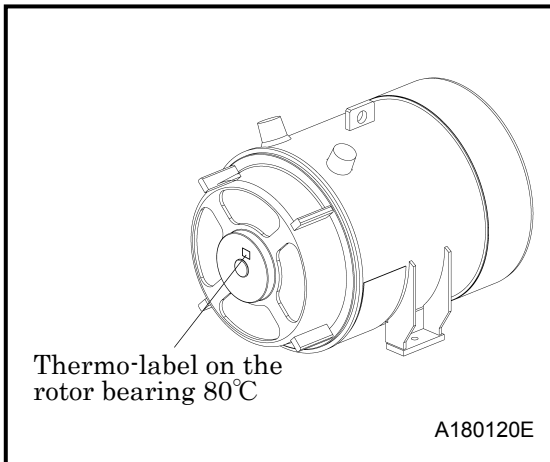

- Replace thermo-label if it has changed color.
- When replacing, contact our office or distributor.

5.4.10 Drain Water from Fuel Tank

Every 250 hours

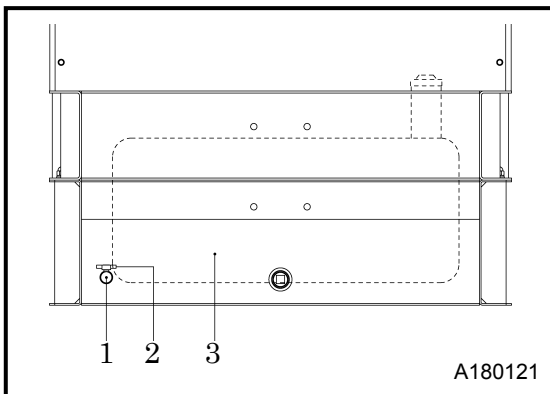

- To drain fuel tank, remove drain plug [1], and open drain valve [2] to drain the condensate accumulated in fuel tank [3].
- After making sure that all condensate is completely drained out, close drain valve firmly and install drain plug.
- Dispose of condensate according to the designated regulations.

5.4.11 Change Fuel Filter Element

Every 500 hours

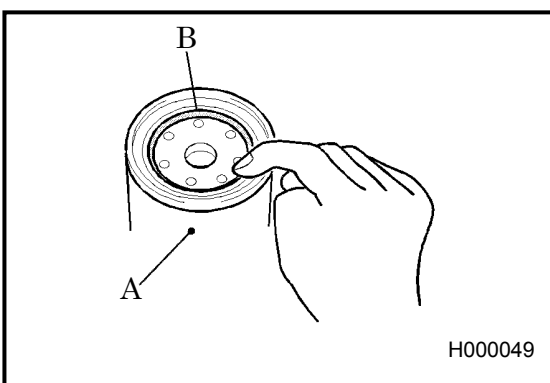

<Procedure>

1. Take out the filter case [A] using a filter wrench.
2. After coating fuel on the new fuel filter packing [B], screw it in. **(For part number, See Section 5.3)**
3. After the packing touches the sealing face, tighten another 2/3 turn with a filter wrench.
4. Bleed air from fuel. **(See Section 3.5.5)**
5. After installing the fuel filter, check it for any leak during operation.

5. Periodic Inspection/Maintenance

5.4.12 Change Fuel Pre-Filter Element

Every 500 hours

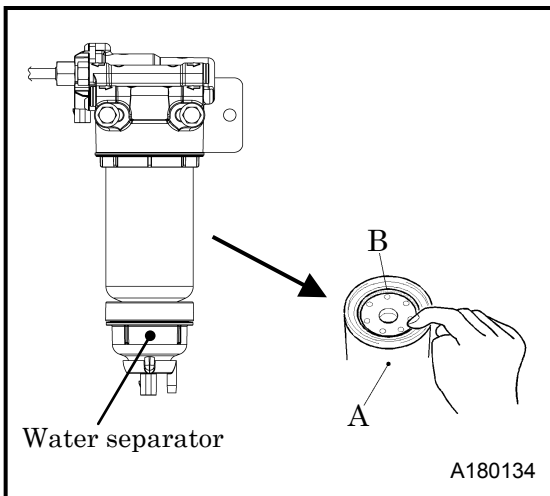

<Procedure>

1. Drain the condensate completely from the water separator. **(See Section 3.4.4)**
2. Take out the filter case [A] by using a filter wrench.
3. After coating fuel on the new fuel filter packing [B], screw it in. **(For part number, See Section 5.3)**
4. After the packing touches the sealing face, tighten another 2/3 turn with a filter wrench.
5. Remove air from the fuel. **(See Section 3.5.5)**

5.4.13 Clean Outside of Radiator and Intercooler

Every 500 hours

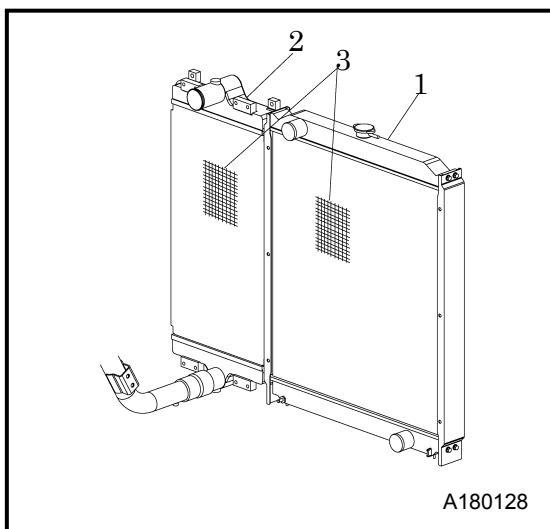

- When the fin tubes [3] of radiator [1] and intercooler [2] are clogged by dust or other foreign materials, the heat exchange efficiency drops and this will raise coolant temperature. These tubes and fins should be cleaned depending on the state of dirt inside the tubes even before maintenance schedule.
- Do not use high pressure washer for cleaning as it may damage fin tubes [3].
- When the unit is used or installed near seaside or onboard a boat, clean the radiator using fresh water at least than once a month.

5.4.14 Drain Condensate out of Intercooler

Every 500 hours

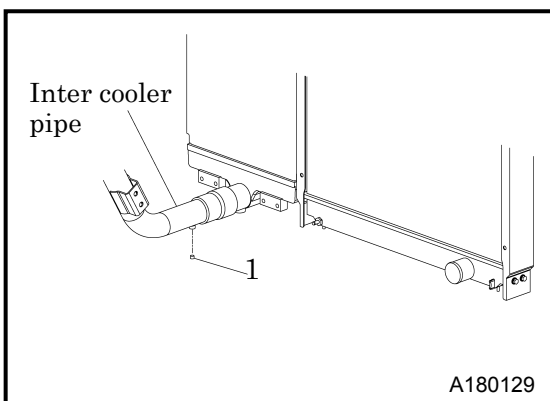

- Remove drain plug [1] below intercooler to drain condensate.
- After finishing drainage, install drain plug [1].
- Dispose of condensate according to the designated regulations.

5. Periodic Inspection/Maintenance

5.4.15 Check Terminals and Connections

Every 4 months or every 500 hours

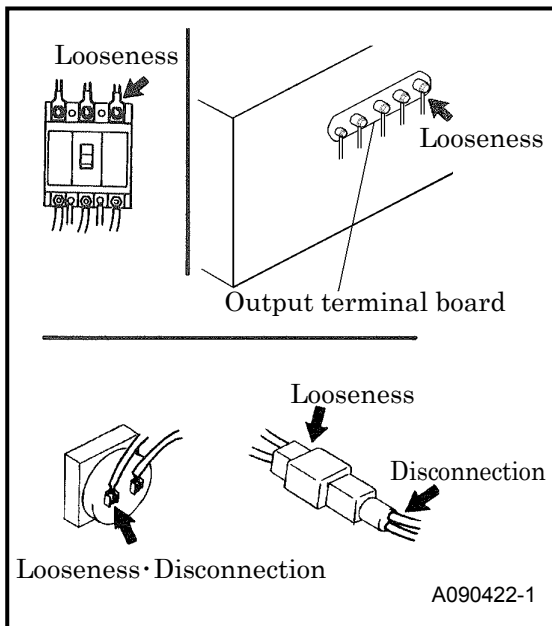

Check for any looseness on the cables, any damage on insulated covers, and disconnection, disconnected cables, or short-circuits etc.

[Checking points of electrical circuits on the generator side]

- Terminal connection of 3-phase output terminal plate.
- Main circuit of circuit breaker.
- Terminal connection on control box.
- Each terminal connection of each instrument.

[Checking points of electrical circuits on the engine side]

- Portion of connectors to the engine.
- Check for looseness of terminal connections.
- Rubbing and wear of the wire.

5.4.16 Check for Cracks and Leaks on the Exhaust Pipe

Every 4 months or every 500 hours

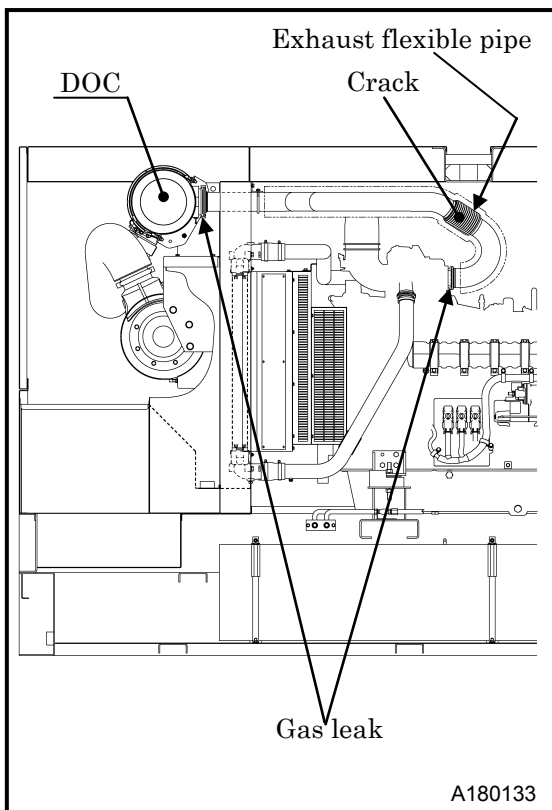

- Please check the flexible pipe between the DOC and engine exhaust outlet for cracks and exhaust gas leakage.

- If any leak is found, take care to avoid getting burned by exhaust gas.

5. Periodic Inspection/Maintenance

5.4.17 Change Air Filter Element

Every 1,000 hours

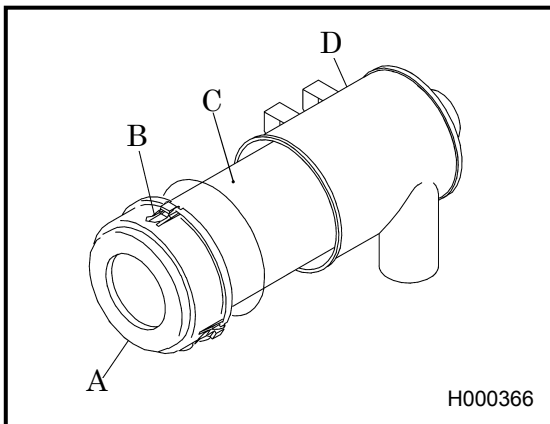

<Procedure>

1. After removing the cap [A] by loosening its cap fixing latch [B], clean its interior properly.
2. Remove the element [C] and then replace it with a new one. **(For part number, See Section 5.3)**
3. When installing the cap after replacing it, firmly push the element into the case [D] by hand and make sure that the hooks of the cap fixing latches are securely attached and tightened.

IMPORTANT

- The air filter is crucial to machine's performance and life.
Be sure to use genuine parts.

5.4.18 Change of OCV Filter

Every 1,500 hours

<Procedure>

1. Remove cap [B] of OVC filter [A] by rotating it counterclockwise. Remove the filter element from the inside.
2. Install a new filter element and then screw on the cap [B]. **(For part number, See Section 5.3)**

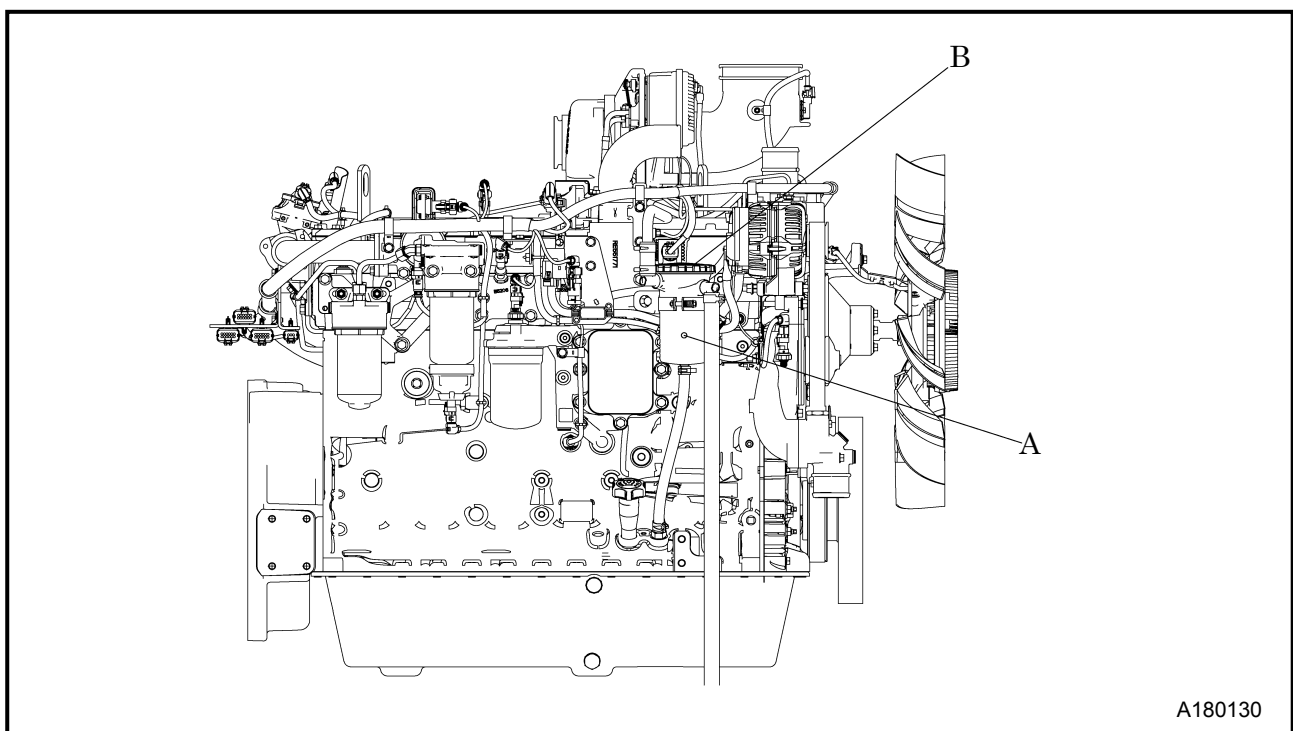

5. Periodic Inspection/Maintenance

5.4.19 Clean Oil Fence

Every 1 year or every 1,000 hours

Expert knowledge is required to clean the inside of the oil fence and to check it for rust. Contact your local service center.

<Procedure>

1. Remove the fuel pipes and electric wire connected to the fuel tank.
2. Remove the eight nuts connecting the oil fence to the machine.
3. Using a crane and the lifting bail, lift up the machine to separate the oil fence from the machine.
4. Check and clean the inside of the oil fence.

- Check the inside of the oil fence for dust, fur, and other foreign matter and check it for any rust.
 - When the oil fence is found rusted, remove the rust and re-paint the affected area.
 - Should any leakage be found, contact your dealer directly.
5. Check whether the seal rubber attached on the top of oil fence is slanted or curved.
 6. Realign the machine and the oil fence, replacing the 8 bolts and tightening them securely.
 7. Install fuel pipes and also electric wires.

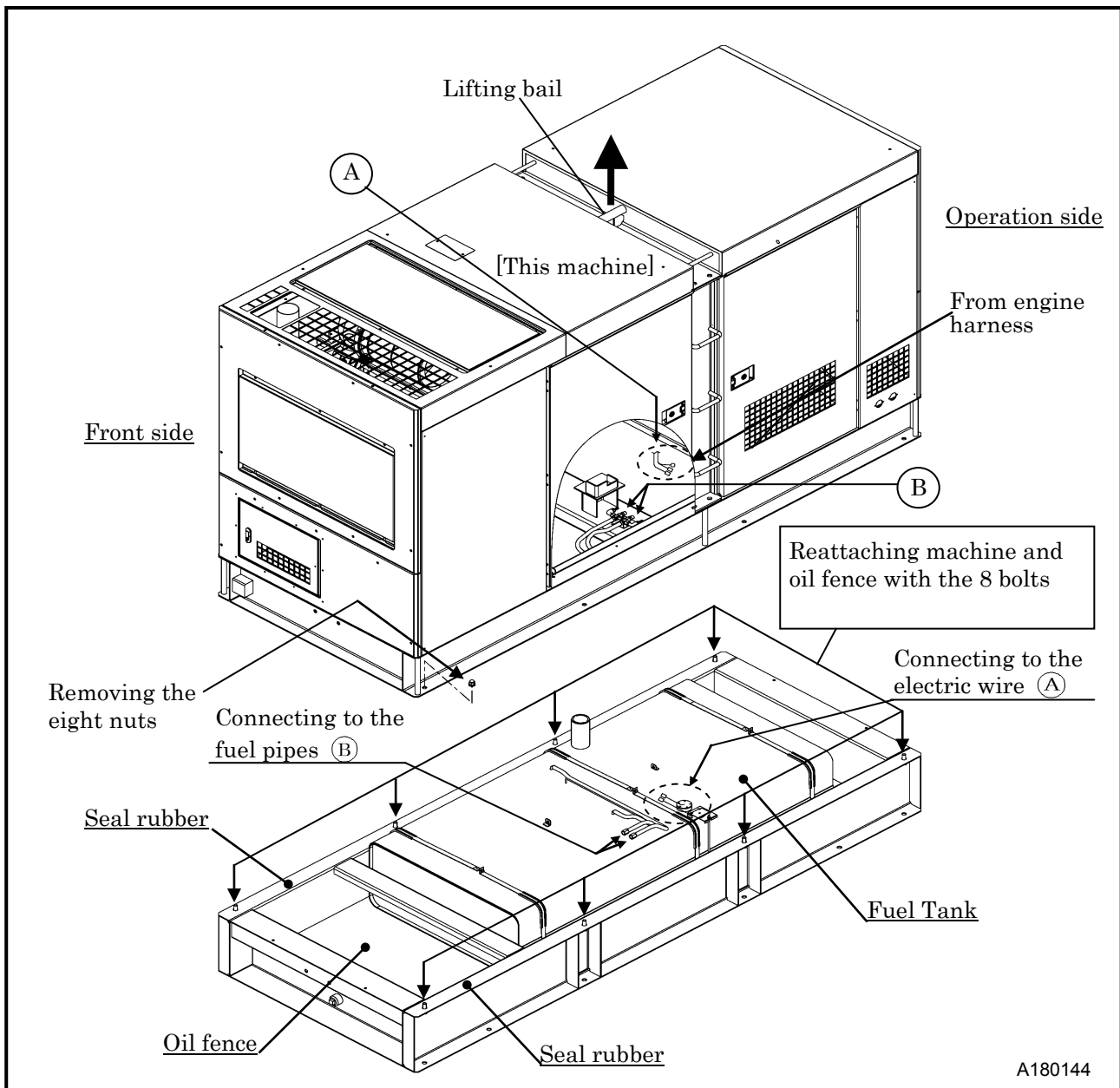

A180144

5. Periodic Inspection/Maintenance

5.4.20 Check Vibration Isolators

Every 1 year or every 1,000 hours

- The vibration isolation rubber [1] is used for the support of generator and engine. Check the rubber for any damage or deterioration due to oil sticking.

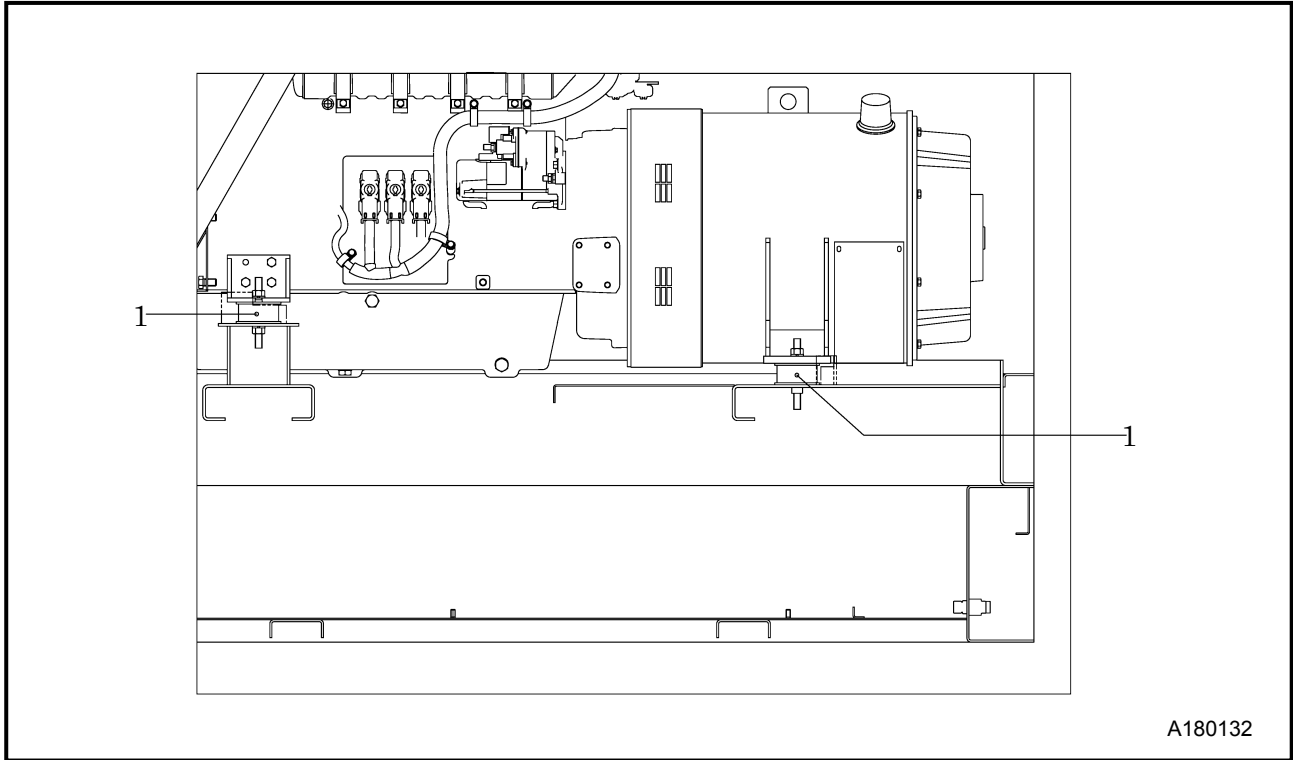

5.4.21 Check Each Rubber Hose

Every 1 year or every 1,000 hours

- Check all the rubber hoses for hardening, cracks, and fissures.
- If any hardening, cracks, or fissures are found on a hose (air filter, radiator, fuel and drain), replace it with a new one.
- Check each hose clamp and if any loose hoses are found, retighten them.
- Even before the maintenance interval comes, replace hoses if hardening, cracks, or fissures are found. When replacing, contact your distributor for parts.

5. Periodic Inspection/Maintenance

5.4.22 Change Coolant (LLC)

Every 2 years

When removing the surge tank pressure cap, be sure to stop the machine and wait until the coolant cools down.

<Procedure>

1. Remove the two bolts securing the inspection cover on top of bonnet [A].
2. To drain coolant, remove surge tank pressure cap [B], and then loosen the radiator drain valve [C].
3. After draining, close drain valve [C] and supply water from the surge tank.

[Water supply: about 27L]

4. Install the inspection cover on the bonnet.
5. After changing the coolant, operate the machine for 2 to 3 minutes at the unloaded condition and stop it. Then check the coolant level again, and replenish it if level is low. Repeat as necessary.

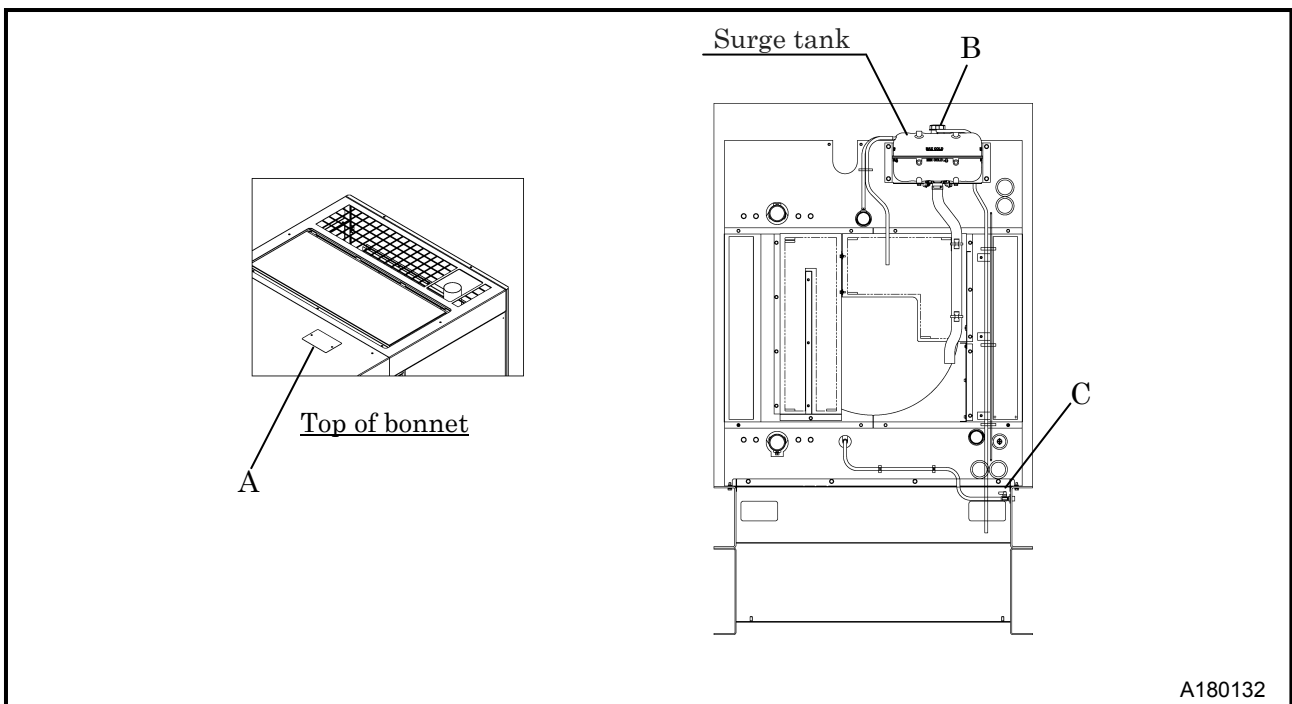

Upon changing coolant

CAUTION

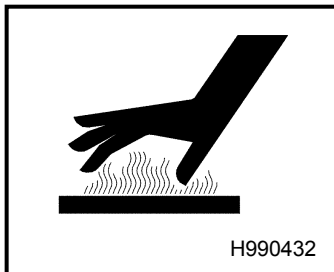

- When removing the surge tank pressure cap, be sure to stop operation and wait until the coolant cools down.
- LLC (Antifreeze) is a toxic material.
- If it should be swallowed by mistake, it is necessary to see a doctor immediately instead of being sent out enforcedly.
- When a person gets LLC (Antifreeze) in his eyes, wash the eyes with clean running water and make him see a doctor immediately.
- When LLC (Antifreeze) is stored, put it in a container with an indication saying "LLC (Antifreeze) inside" and seal it up, then Keep it in a place away from children.
- Beware of flames.

5. Periodic Inspection/Maintenance

5.4.23 Change DEF Dosing Unit Filter

Every 4,500 hours

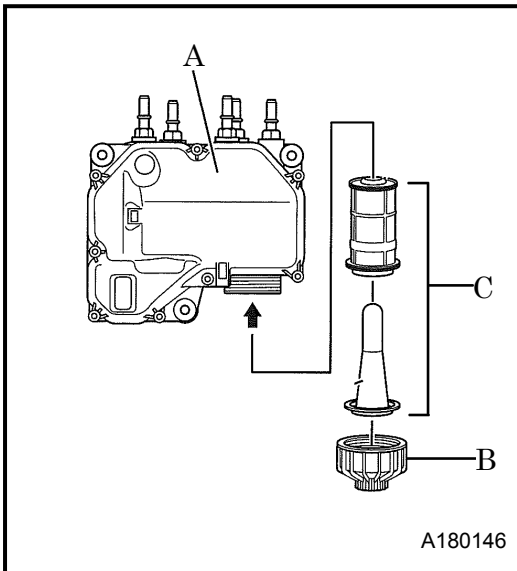

<Procedure>

1. Set a pan under supply module [A], loosen cover [B], and pull it out together with DEF Dosing Unit Filter [C].
2. Assemble a new DEF Dosing Unit Filter [C].

(For part number, See Section 5.3)

3. Lastly, secure cover [B].

IMPORTANT

- Reuse of the DEF Dosing Unit Filter may cause trouble. Be sure to replace it with a new one.
- Always replace the DEF Dosing Unit Filter as a set.

6. Storage and Disposal

6.1 Preparation for Long-term Storage

When the machine is left unused or not operated longer than half a year (6 months), store it in a dry place free of dust after the following treatments have been done to it.

- Put the machine in an enclosure if it is stored outside. Avoid leaving the machine outside with a sheet cover directly on the paint for a long period of time, or this will cause rust to the machine.
- Perform the following treatments at least once every three months.

<Procedure>

1. Discharge existing lubricant from the engine oil pan. Pour new lubricant in the engine to clean the internals of the engine. After running it for a while, drain it again.
2. Spread lubricant on each moving part.
3. Completely charge the battery and disconnect grounding wires. Remove the battery from the machine, if possible, and store it in a dry place. (Charge the battery at least once every month.)
4. Discharge coolant and fuel from the machine.
5. Seal air-intake port of engine and other openings like the muffler with a vinyl sheet, packing tape, etc., to prevent moisture and dust from getting in the machine.
6. Measure the insulation resistance of the generator, and make sure that it is more than $1M\Omega$.
(See Section 5.4.8)
7. Be sure to repair any trouble and maintain the machine so that it will be ready for the next operation.

6.2 Disposal of Product

- When disposing of this machine, first drain the cooling water and oils. If you require any additional instruction or advice, please contact our office or distributor.

7. Specifications

7.1 Specifications (not including trailer)

Model		MP150 T4F			
Generator	Exciting system		Brushless		
	Armature connection		Star with Neutral	ZigZag	
	Phase number		3 Phase-4 wires	1 Phase-3 wires	
	Power factor	%	80	100	
	Frequency	Hz	60		
	Rated output	kVA(kW)	150(120)		
	Voltage	V	240	480	240/120
	Amps	A	361	180	363
Engine	Model		JOHN DEERE 6068HFG05		
	Type		4 Cycle, water cooled, direct injection, Turbocharged, EGR		
	Aftertreatment		DOC+SCR		
	Number of cylinders		6		
	Displacement	cu.in.(L)	415(6,800)		
	Output	Hp(kW)	235(175)		
	Engine speed	min ⁻¹	1,800		
	Lubricating oil capacity	Gal.(L)	8.7 (33.0)		
	Coolant capacity (including radiator)	Gal.(L)	7.1 (27.0)		
	Battery		150Ah × 1(12V)		
	Fuel tank capacity	Gal.(L)	204 (772)		
	DEF tank capacity	Gal.(L)	11.7 (44.2)		
Dimensions	Overall length	in.(mm)	130 (3,300)		
	Overall width	in.(mm)	51 (1,300)		
	Overall height	in.(mm)	84.6 (2,150)		
	Net dry mass (weight)	lbs.(kg)	6,878 (3,120)		
	Operating mass (weight)	lbs.(kg)	8,488 (3,850)		
Others	The capacity of oil fence	Gal.(L)	116(440)		

Addendum A - Transporting and Set-Up



Read entire Operator's Manual before you attempt to setup, transport, or operate your new towable generator.

Your towable generator is ready for use after it has been properly set up with the recommended oil and fuel. If you have any problems with the setup of your towable generator, contact your authorized dealer

Transporting



WARNING When loading and unloading the unit, be sure to use the lifting bail (B) located at the top center of the unit.

- Never get under the unit when lifted.
- Never lift the unit while in operation.
- If the unit is transferred by truck, fasten it by ropes at the front eye and rear stand. Also be sure to place a set of chocks against the front and rear of each wheel.

Lifting the Generator

Before lifting the unit, make sure to check the lifting bail for any cracks, loose bolts, etc.

1. Connect the hook (A) of the crane or shackle with the lifting bail (B) eye fitted at the top center of the unit. Ensure there is no person standing around the unit. Then perform hoisting operation.
2. Select a truck or crane with capacity sufficient for the weight and size of the unit. See **Specifications**.
3. Never hang anything from generator while lifting. Bail is designed to carry only weight of generator.

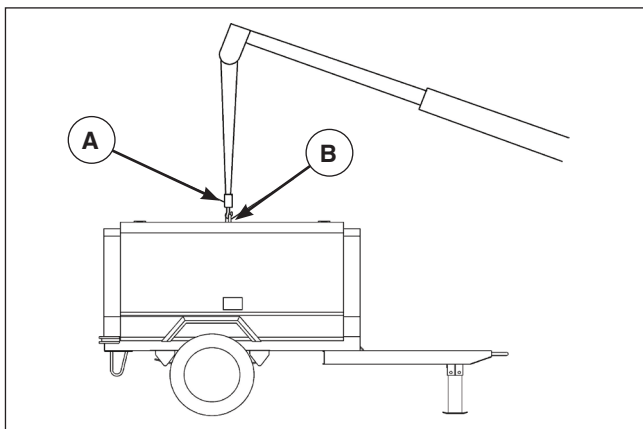

Towing the Generator



WARNING Before towing the machine, make sure to check and confirm the following points. Failure to follow the instructions below, could result in serious injury or death.

- Proper tire air pressure.
- Tire lug nuts are not loose.
- Tires are not worn or damaged.

- Make sure that the end of the drawbar is securely connected to the coupler of the towing vehicle.
- Make sure there is no damage to the towing vehicle and the drawbar of the machine.
- Make sure to keep hands and fingers away from any part of the coupling device when coupling or uncoupling a drawing device to a draw bar.
- Make sure the height of the hitch is adjusted so that the trailer is level while connected to the tow vehicle.
- Make sure to drive the towing vehicle safely.

Set-Up



WARNING

- Exhaust gas from the engine is poisonous, and could cause death when inhaled.
- Avoid using the machine in an insufficiently ventilated building or tunnel.
- Do not position the exhaust gas outlet in the direction of a person or building.

The machine should be operated in the following conditions:

- Ambient temperature 5°F to 104°F (-5°C to 40°C).
- Humidity less than 85%.
- At altitudes lower than 3,281 ft (1000 meters) above sea level.
- Set up the machine in a place with good ventilation, lower temperature, and with surroundings as dry as possible.
- If more than two machines are placed parallel in operation, keep enough distance so that exhaust air from one machine does not affect the other.
- Set up the unit in an area where fresh air is always available.
- Keep enough space around the unit for inspection and maintenance access.



WARNING The machine must be parked horizontally on a level surface. If the machine must be parked on a slope, place it across the grade to prevent rolling. Do not park on a slope exceeding 15°. Be sure to place wheel chocks (C) against the front and back of each wheel.

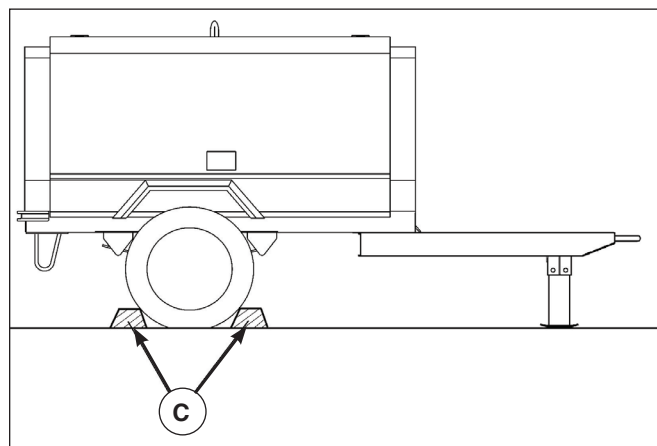

Grounding



- Failure to properly ground the unit could result in death or serious injury. Be sure to properly ground the unit before operation.
 1. Using a mallet, install a grounding rod (A) firmly into the ground, less than 5 feet (1.5 m) from the unit's grounding terminal (B).
 2. Connect the grounding rod cable to the grounding terminal.

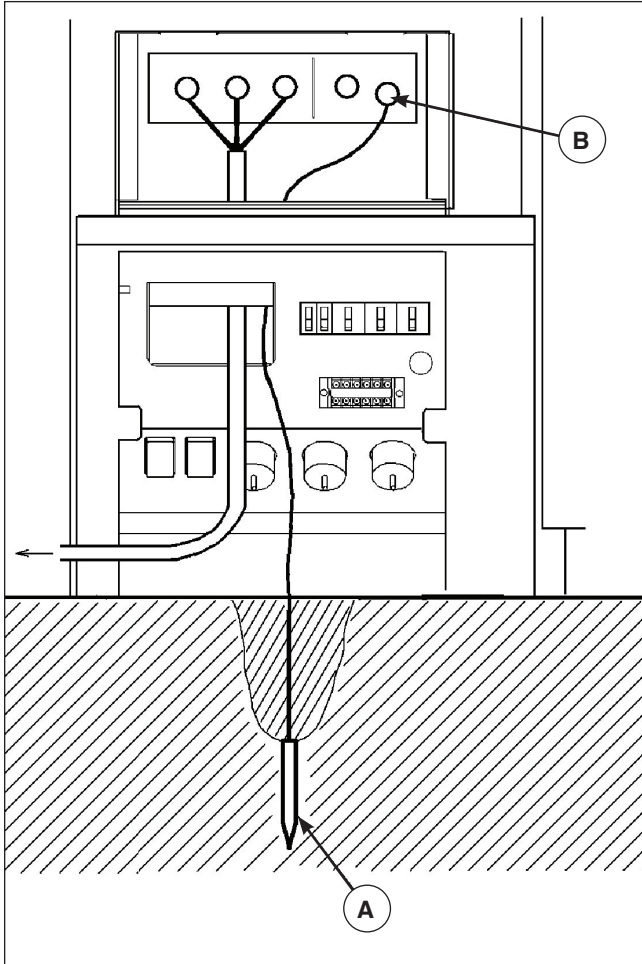

Selecting Cable

- Select a cable (C) with sufficient diameter by considering the permissible current on the cable and the distance from the generator to the load (D).
- If the current flowing to the load exceeds the permissible current of the cable, resultant overheating may burn the cable. Similarly, if the cable is too small in thickness to the length, the input voltage to the load will fall to cause the load input power to drop, as a result, the performance of the machine cannot be displayed.

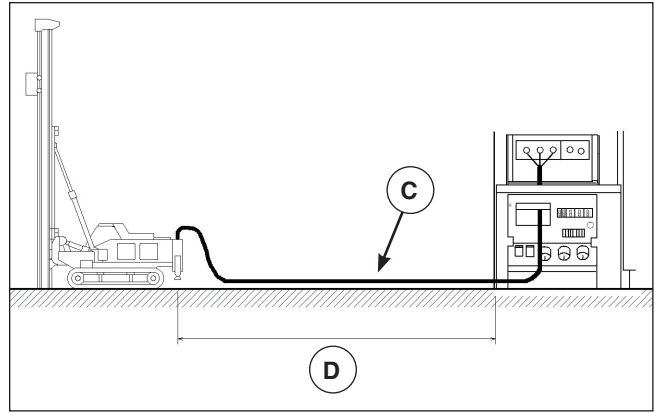

- Below is a simplified three-phase three-wire formula to seek voltage drop or cross-sectional area of the cable from cable length and working current. Select such a cable length and thickness so that the voltage drop will remain less than 5%.

Output system	Voltage drop	Cross-Sectional Area of Cable	e: Voltage drop (V) e ¹ : Voltage drop between outside line or one line of each phase and neutral line
Three-phase 3-wire Type	$e = 30.8 \times L \times I / 1000 \times A$	$A = 30.8 \times L \times I / 1000 \times e$	A: Cable thickness (mm ²)
Three-phase 4-wire Type	$e = 17.8 \times L \times I / 1000 \times A$	$A = 30.8 \times L \times I / 1000 \times e^1$	L: Cable length (m) I: Working current (A)

- The following tables show the relations between the cable length and the cable thickness (nominal cross-sectional area) suited to the working current. (Based on the condition that working voltage is 200 V, with voltage drop of 10V.)

Single-Conductor Cable (Unit: in² (mm²))

Length (ft (m)) / Current	164 (50)	246 (75)	328 (100)	410 (125)	492 (150)	656 (200)
150A	0.06 (38)	0.06 (38)	0.08 (50)	0.09 (60)	0.12 (80)	0.16 (100)
200A	0.09 (60)	0.09 (60)	0.09 (60)	0.12 (80)	0.16 (100)	0.19 (125)
300A	0.16 (100)	0.16 (100)	0.16 (100)	0.19 (125)	0.23 (150)	0.31 (200)
400A	0.19 (125)	0.19 (125)	0.23 (150)	0.31 (200)	0.31 (200)	0.39 (250)

Three-Conductor Cable (Unit: in² (mm²))

Length (ft (m)) / Current	164 (50)	246 (75)	328 (100)	410 (125)	492 (150)	656 (200)
150A	0.03x2 (22x2)	0.03x2 (22x2)	0.06x2 (38x2)	0.06x2 (38x2)	0.08x2 (50x2)	0.08x2 (50x2)
200A	0.06x2 (38x2)	0.06x2 (38x2)	0.06x2 (38x2)	0.08x2 (50x2)	0.08x2 (50x2)	0.09x2 (60x2)
300A	0.09x2 (60x2)	0.09x2 (60x2)	0.09x2 (60x2)	0.09x2 (60x2)	0.12x2 (80x2)	0.16x2 (100x2)
400A	0.09x2 (60x2)	0.09x2 (60x2)	0.09x2 (60x2)	0.12x2 (80x2)	0.16x2 (100x2)	0.19x2 (125x2)

Fuel Pipe Selector Valve



WARNING

- Monitor the fuel feeding conditions while feeding fuel from a separate fuel storage tank.
- Do not switch the selector valve to the external tank position unless an external tank is being used. Fuel pipe damage and fuel leakage may result.
- Do not use excessive force operating the selector valve handle. Valve damage and fuel leakage may result.

This valve is designed to feed fuel to the engine from an external fuel storage tank.

Operation

1. Unit is delivered from factory with fuel line piping and selector valves set as shown (E). When operating the unit using installed fuel tank, run the machine with the fuel line piping and selector valves with the factory-arranged settings.
2. When using a separate storage tank (F), remove the plugs (G) fitted at the connections to the separator tank and make piping connections as shown (H). Then switch the selector valve handle as shown (I).
3. When removing the external tank, make sure to return the selector valve handle to the original position (E), remove the external tank piping connections, and reinstall the plugs.

Installation of Separate Storage Fuel Tank and Piping

1. Use oil resistant fuel hose with inside diameter of 8mm to 10mm.
2. Install the fuel tank so that the fuel level of the tank may be kept at a level 0 - 98" (0 - 2.5m) higher than the machine.
3. In order to avoid suction of water and sediment, install the suction and return pipe so that the inlet ports are 0.6 - 0.8" (15 - 20mm) higher than the bottom of the tank (F).
4. When refilling fuel in the tank, be careful to not mix water and sediment.

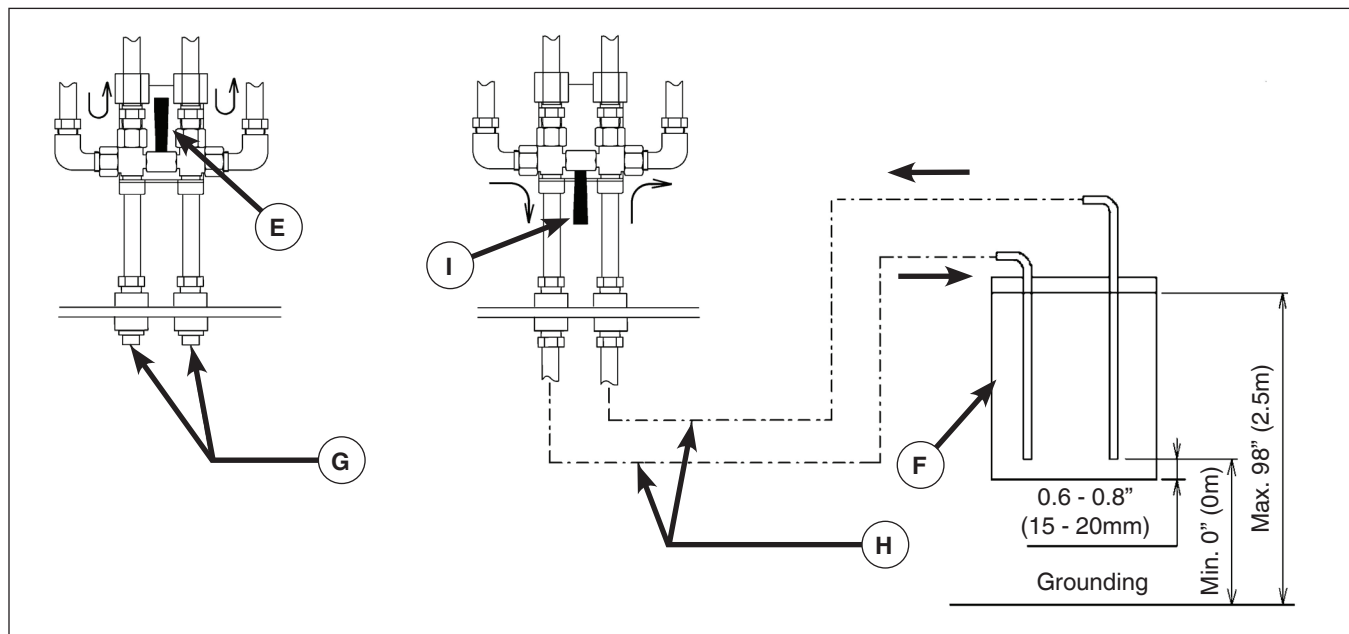

Addendum B - Cam Locks / Arctic Kit

NOTE: Location and configuration of kit components may differ according to model.

Cam Lock Receptacles

The cam lock receptacles allow for quick connection and disconnection of loads.

1. Connect the cam lock connectors from the load to the cam lock receptacles on the lower portion of the outlet panel on the unit. See Figure B1. Be sure to connect the load correctly. See **Connecting Loads**.

NOTE: Some models are equipped with a double row of cam locks.



WARNING

Electrocution Hazard. Do not connect or disconnect loads to the cam lock receptacles while the unit is in operation.

NOTICE: Do not operate the voltage selector switch while the unit is in operation. Unit damage may result.

Arctic Kit

Block Heater / Battery Heater

The block heater / battery heater keeps the engine block and battery heated while the unit is not in use.

The block heater / battery heater should be used whenever the unit is not in use in temperatures below 32° F (0° C).

1. Plug the female end of a heavy-duty power cord (not supplied) into the Block Heater / Battery Heater recessed receptacle (A, Figure B2).
2. Plug the male end of the power cord into a standard 120V outlet.
3. Unplug the block heater / battery heater before putting the unit into operation.

Battery Charger

The battery charger keeps the battery charged while the unit is stored or not in use.

1. Plug the female end of a heavy-duty power cord (not supplied) into the Battery Charger recessed receptacle (B, Figure B2).
2. Plug the male end of the power cord into a standard 120V outlet.
3. The red light (A, Figure B3) on the battery charger module, located in the left front section of the engine compartment (see Figure B3) indicates the battery is charging. The green light (B) indicates full charge. (The battery charger can stay plugged in after the battery reaches full charge without damaging the battery.)
4. Unplug the battery charger before putting the unit into operation.

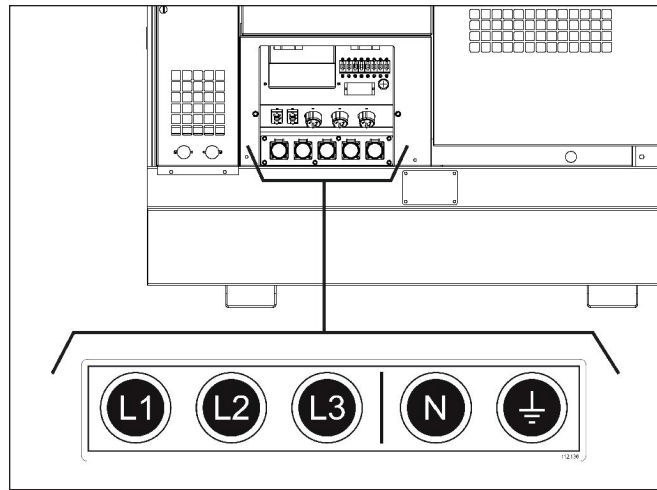

Figure B1

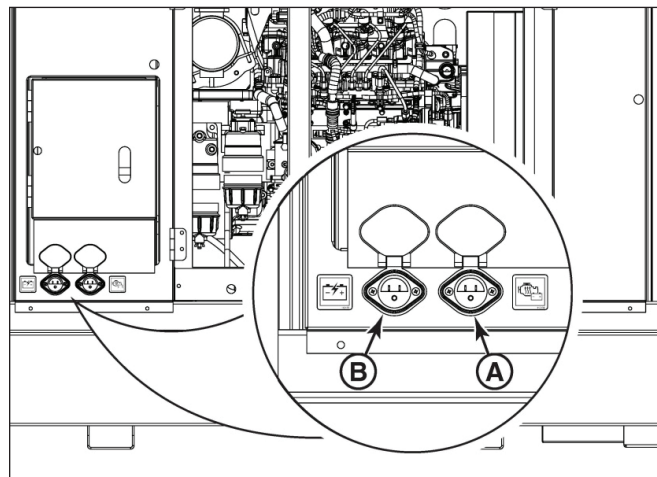

Figure B2

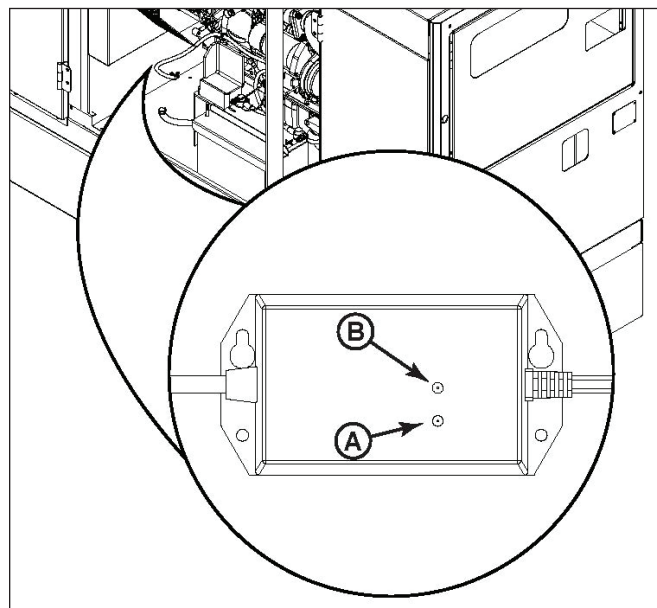

Figure B3

